

The Officers:

President: Ken Myers 1911 Bradshaw Ct. Walled Lake, MI 48390 phone: (248) 669-8124	Vice-President: Richard Utkan 240 Cabinet Milford, MI 48381 phone: (248) 685-1705	Secretary/Treasurer: Debbie McNeely 4733 Crows Nest Ct. Brighton, MI 48116 phone: (810) 220-2297
Board of Directors: Keith Clark 2140 E. Highland Rd. Howell, MI 4848843 phone: (517) 546-2462	Board of Directors: Jeff Hauser 18200 Rosetta Eastpointe, MI 48021 phone: (810) 772-2499	Ampeer Editor: Ken Myers 1911 Bradshaw Ct. Walled Lake, MI 48390 phone: (248) 669-8124

Ampeer subscriptions are \$10 a year U.S. & Canada and \$17 a year world wide.

The Next Meeting:
Date: Thursday, August 7 Time: 7:30 or ASAP
The Rushton Road Flying field, South Lyon, MI
Located between 9 Mi. & 8 Mi. , east side of Rushton Rd.

Ampeer

Care and Feeding of Trexler Balloon Tires

from Tom Wilk
 301 W. Redwing St.
 Duluth, MN 55803-1711

A while back I mentioned problems with blowing up Trexler tires with your mouth. Tom wrote to say:

Regarding Trexler balloon tires filler tubes becoming stuck when filling by mouth, this can also happen when using an air pump. First off I suck up a bit of talc before filling the tires - this helps preventing the filler tubes from sticking.

If they are stuck, get your soldering iron warmed up, using your pump tet a bit of air into the filler tube, then gently warm the tube with the soldering iron, **but don't touch the tube!** You will find that the tube will open and look as good as new. With the pump, suck up some talc and coat the fill tubes before refilling them.

Thanks for the tip Tom. km

The May Meeting

The may meeting had quite a few kits and planes under construction show up. We viewed the kits and then Ken discussed the last part of selecting the motor/prop/battery combinations for the planes.

Gus Nuereberg of Farmington Hills had his underconstruction WACO from RCM plans. The plane should be ready to fly at 5.5



lbs. It uses an Astro Flight 25G motor and two 8 cell 1800mAh packs in series. The wing loading should be about 15 oz./sq.ft. with 606 sq.in. of wing area. Another shot of Gus's plane, with the cowl removed appears on the next page.

What's in this issue?

Trexler Tyres - The May Meeting - How Fast Does It Fly? - H-100 from Modelair-Tech - Computer Use - Plane Ratings from Sweden - Chip Rating - Hitec Radio Sources - Bill Grigg's Model's Update - News from the Gulf States - Shield's Ratings - CIE Fly-In - Grife's Extra - New Prop Book - Simple On/Off Switch - June EFO

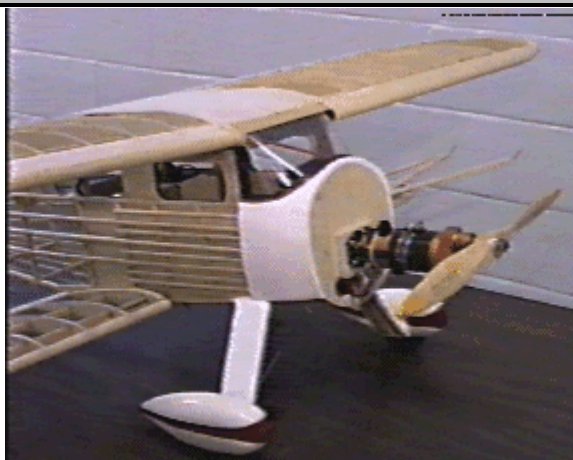

Mike Wizynajts of Lynden brought in Sig's little sailplane kit for S400 and Jim Ryan's kit of the P-38 for twin S400s. After some discussing, Mike thought he might power the Sig sailplane with an AP-29. In the picture, Mike is holding the fuse

for the Sig sailplane to be converted to electric.

Mike also showed off the laser cutting on the P-38 kit. He's really excited about this one.

Ken Myers brought in the very complete kit of the

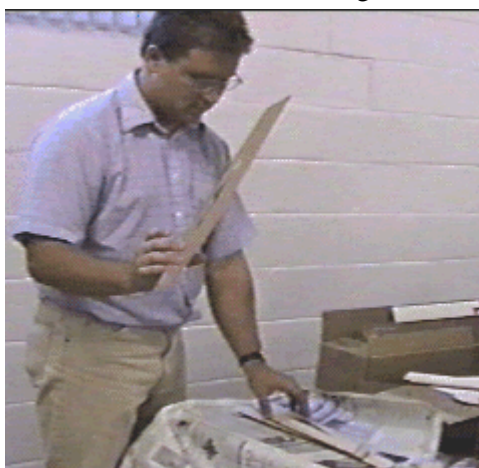

SR Batteries X440. Doug and Al look it over. Everyone remarked about the excellent quality. Ken and

Richard have to get on the stick and get this one in the air!

How Fast Does It Fly??

Clay Ramskill, 5709 Trails Edge Coon
Arlington, TX 76017

<http://www.startext.net/homes.cramskill/rcclub.htm>
via the AMA newsletter

One of the first questions asked of us by non-modelers! And one for which we seldom have any accurate answer, unless we have access to a friendly cop with a radar gun.

Actually, a lot of us, perhaps secretly, would like to know (just for grins) how fast our planes DO fly. Aside from that radar gun, there are ways to find out; the most obvious is to set up a timed run over a known distance, but that's a lot of trouble.

Without too much trouble, though, we can get a pretty good estimate by knowing our engine RPM and the pitch of our prop. Naturally we can tach the RPM on the deck, but knowing how much extra RPM we pick up in the air is part of the estimating process. It will all depend on your engine, the prop, and how slick your airplane is. If you assume you'll gain 1000 RPM, 2000 if your plane is pretty fast, that will put you in the ballpark.

Let's take an example: a relatively medium-drag airplane, powered by a .40 which tachs a 10 x 6 prop at 13,000 RPM on the ground, and we'll assume 14,000 at speed. The 6" pitch means that at best (a perfect prop!) The plane will move 6" for every revolution that's half a foot. $14000 \text{ RPM} = [14000/60 =] 233 \text{ RPS}$ (revs per second) multiply that by .5 feet per rev, and we get 116 feet per second. Converting to miles per hour ($60 \text{ mph} = 88 \text{ fps}$), we have $116 \times 60/88 = 79 \text{ mph}$.

A similar, but slicker plane turns a 9 x 7 at 13500 RPM assuming 2000 RPM pick up at high speed, we get: $1550(3/60 = 258 \text{ RPS}, \times 7/12 \text{ ft./rev} = 150 \text{ ft./sec.}$ Converting to mph, $150 \times 60/88 = 102 \text{ mph}$.

In the past, we would have taken off about 10% for prop slippage at this point, after all, no prop can be perfect. But use of in-flight data systems has shown that top speeds are closer to the calculated figures than initially thought. This is because most props, using cambered airfoils, still have a positive angle of attack, and thus develop thrust, at their nominal pitch speed. Thus, a 7" pitch prop may have to go up to a 7-1/2 or 8 inches per rev before thrust falls to zero.

Note that the internal timing of most sport engines is

such that they don't produce much usable power above 16-17 thousand RPM. So, beware of claims of well over 100 mph with a non-racing plane, unpiped sport engine, and a sport prop! Perhaps possible-but highly unlikely!

From Modelair-Tech

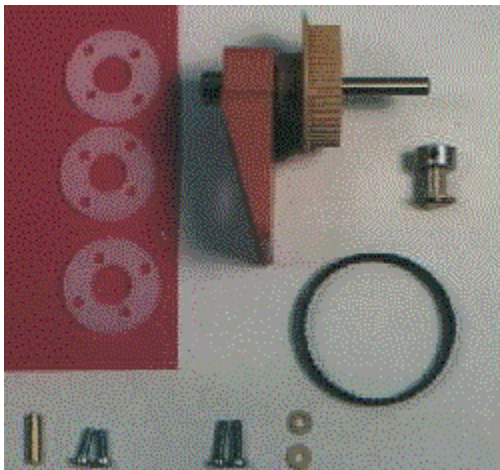

Modelair-Tech announced the release of a new belt drive for the popular Graupner "Speed 400" class motors and the Kyosho AP-29/Graupner Speed 480. As in all other MA-T belt drives the

shaft is made of steel and supported on dual-shielded, long-life ball bearings. The stout 3/16" shaft accepts popular "prop adapters" from Leisure or Master Airscrew gearboxes. The prop adapter will be furnished upon request at an additional charge. Two ratio ranges are available. With a 36 tooth prop shaft pulley and a 50 tooth belt, ratios available will be; 2.57:1, 3:1, 3.27:1 and 3.6:1 with just the change of the motor pulley. With a 48 tooth prop shaft pulley and a 58 tooth belt, ratios will be; 3.43:1, 4/1, 4.36:1 and 4.8:1 with just the change of the motor pulley. These two ranges should allow the modeler to "fine tune" the performance of any Speed 400/AP-29/Speed 480 powered model. The unit can be "beam" mounted to any model with a pair of wooden beams such as used in glow applications. The beams must be 1" apart. In the near future, MA-T will offer injected molded beams specifically designed for the H-100.

Suitable applications for this drive are: 300-450 sq in Old-Timer and Nostalgia models. 250-350 lightly built scale models ("Golden Age" type). Larger multi-motor models desiring larger propellers or "scale number of blades". Single motor models should weigh between 16-30 ounces, and multi's can weigh as much as a few pounds.

Extra long shafts can be made available for those needing to mount the drive farther aft in the fuselage for slender nose "sailplane" applications.

The unit is listed in their catalog at \$39.95 and the prop adapter at \$5.00. Please add \$4.00 S+H for a single unit. \$6.00 S+H for 2 or more.

MODELAIR-TECH

P.O. BOX 1467

Lake Grove, NY 11755-0898

Phone & FAX (516) 981-0372

Send E-mail to THunt95147@aol.com

Computer Use

Many of you are already using computers to help you design and power electric models. They are also helping you gather information on electric flight. For those of you who have not used a PC, I can't urge you enough to try it. Many of you are retired or on fixed incomes, and I understand this is a problem, but many of you also have sons and daughters who have two or more PC's and some they may not be using. Why don't you suggest that you'd like to learn a bit more about computers to them, and see what they do. You just might end up with a useful tool!

Be sure that it is at least a 486 with Windows and you can run ElectriCalc, and by investing in a modem, you'll be able to keep abreast of the latest developments via the World Wide Web. You won't regret it.

To get you going, here's a list of WEB sites you might like to visit: (don't worry about the funny looking http:// stuff, it is just an "address", and that's all you need to get there and start looking and learning)

<http://members.aol.com/KMyersEFO/>

<http://web2.airmail.net/warner1/deaf/index.htm>

<http://www.adobe.com/acrobat>

<http://www.aveox.com>

<http://www.ezonemag.com>

<http://www.geocities.com/CapeCanaveral/Lab/1879/>

<http://www.iquest.net/~weaverr>

<http://www.nasm.edu/NASMDOCS/discinfo.htm>

<http://www.netads.com/com/cabdesigns/>

<http://www.netaxs.com/~mhmyers/vfss.html>

<http://www.ov-1.com>

<http://www.unbeatenpath.com>

<http://www.vipermodels.com>

http://www.wpafb.af.mil/museum/modern_flight/mf48.htm

<http://www2.ari.net/home/waco/wwwhome.html>

<http://wwwcommunique.net/~lakeside/perrethtml>

<http://www.gatewayelex.com/kits2.htm>

By connecting to the EFO site, you'll also get even more places to visit all over the world.

You might like to try AOL (America On Line) first, since it will give you easy, but slow, access to the World Wide Web, while holding your hand. There is also an electric flight forum right on AOL run by Bob Strought. He "hosts meetings" every Wednesday evening on AOL.

Plane Ratings from Sweden
from Stefan Tholin, Vara, Sweden
e-mail at: stefan.tholin@sp.se

Hi Ken,

My name is Stefan Tholin. I live in Vara in southern Sweden. I would like to thank you for providing me and my fellow e-fliers with lots of information.

I have a couple of plane ratings here which you can use if you wish. The descriptions I sent are pretty detailed so delete as you please. Please ask if there are unclear things. I write in Swedish with English words! ;-)

You will find more info about my planes here:
<http://www.geocities.com/CapeCanaveral/Lab/3766/stmoden.htm>
First,

HLG Midway Gnome *** (3) Span 60", Area 375 sq in, 23 oz, 2 channels, Sp400 7.2V or mabuchi 380 (don't know rating), titan 2.6 gear, Falco carbon fiber folder 11.5 x 7, 7 x 500AR, Jeti 30 ESC with BEC, 2 x HITEC 101. Difficult to get all the stuff into such a small plane. 10 - 11 minutes climb and glide flying.



Same plane but different power

HLG Midway Gnome *** (3 - 3.5 slightly better i.e.) Span 60", Area 375 sq in, 23 oz, 2 channels, Sp400 7.2V, Graupner 6x3 folder, 7 x 500AR, Robbe RSC 210 (on/off) with BEC, 2 x HITEC 101. Still difficult to get all the stuff into such a small plane. 9 - 10 minutes climb and glide flying. Why do I believe this one is better? Thermals better and the trim changes when climbing are less pronounced. The 11.5x7 prop blades are bigger than the elevator!

SKYWARD 40 ARF **** (4)

Data: wingspan 160 cm (63"), wing area 47dm² (730 sq in), length 113 cm (44").

Weight of the parts: wing: 0,5 kg, fuselage: 0,6 kg, stab and fin: 0,2kg, undercarriage and misc.: 0,2 kg.
Total weight: 2,9 kg

Motor: Plettenberg HP320/25/6 (HP320K/6), approximately 500 watt

Speed controller: Sommerauer Fuzzy 60, 30 cells ,60 A

Batteries: 14 Sanyo SCRC

Propellor: Aeronaut 12x7 (folder) or Falco 11,5x7 (folder).

The Falco prop gives the longest flight times and very good performance. Propellor rpm is 10000@45A. I have also found that Master Airscrew Scimitar 11x8 (fixed prop) provides good performance though not as good as the Falco folder.

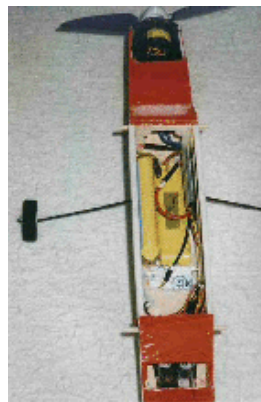

I removed the nose gear and placed the main gear a little bit further forward. I placed a small nylon skid under the tail as protection. The rudder and elevator servo was placed behind the rear former. This gave me more room to adjust the cg by moving the batteries around. I fastened the receiver and the speed controller on the side with Velcro. The receiver battery and the motor batteries (2x7 SANYO SCRC in series) are fastened on the floor with

Velcro too.

The motor is bolted to a plywood former which is screwed to the engine bearers. The rear end of the motor is reaching into a cut out in the firewall. Cooling air is let in through a hole in the firewall and is let out behind the wing.

Take off from grass, loops, rolls and high speed fly bys are all easy to make. It is possible to climb at a very steep angle, but flying time is greatly reduced then. Normal flying times ranges from 7 to 10 minutes. Longest flights so far has been 13 minutes.

If you are going to assemble a SKYWARD 40 ARF I would suggest that you replace the very soft landing gear with ones made of real piano wire or duraluminum. The covering does not strenghten the airframe like ordinary coverings do and it is rather ugly so I think you should consider replacing it.

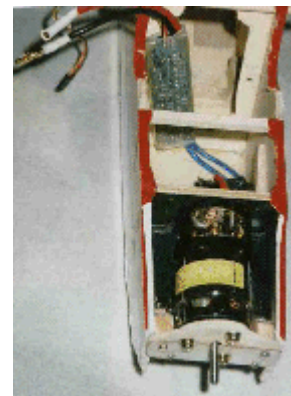

Best Regards,
Stefan Tholin

A Canadian E-Fly

From: Walter Gray

e-mail at: gwr7mm@sympatico.ca

Hi, Ken:

The **EMFSO** fun fly held at the Oakville Model Flying Club field this past Saturday (May 24) was quite successful.

We had 22 pilots register, which while a modest showing, is nevertheless encouraging for a first effort.

More importantly, these pilots brought many nice aircraft including a 1/4 scale cub (lovely, graceful flyer), a non-flying (no water) six engine Dornier flying boat, numerous powered gliders, some of which were easily getting 30-35 minute flight times, some pretty biplanes including Rob Pike's Libery Sport which has been getting so much attention in the E Zone lately about the right prop to use, as well as everything from WWI Camels to WWII Mustangs.

A number of prominent non-electric members of the Oakville Club attended and were impressed by the performance of our electric planes. In a club which is so overwhelmingly non-electric, this is encouraging. We hope to make this an annual event.

Your assistance in spreading the word about the event is most appreciated.

Cheers, Walt

(Sounds like a great time was had by all. Annual event sounds good! Go for it! km)

A Chip Rating

From: Brad Evenson - email at: beverson@sprintmail.com

The aircraft is the *Chip*, Graupner Speed 600BB 8.4, Graupner 8x4.5 folder, 2 S148 servos (ailerons and elevator), 7x1400 SCR, Astro 215 ESC. It is an aileron version of the UHU, but I understand this kit is no longer available in the USA. If you see one for sale, buy it! It is an excellent performer, loves to fly fast and grooves well. The motor and prop used are ideal for this plane, decent power and a long motor run. Battery swapping is easy through the removable canopy. The wing is unusual with the sheeting acting as the spars, it took some time to build. Ailerons more for banking than for fast rolls. Looks great when finished with white Ultracote and the supplied decals as shown on the plans. Rating: *****

Hitec Radio Sources

From: Jim Yuzwalk — email at: jjy@eaglequest.com

Hi Ken,

I really appreciate your feedback. (*We had been discussing what he wanted and my experience - good - with my Focus 4. km*) In fact, I just called Hobby Horse in Madison, WI and ordered a Hitec Prism 7x with the Spectra frequency module. I talked to a guy there named Jim, and he had no problems swapping the four standard servos, that came with the radio, with four Hitec micro HS-80's. He just subtracted the price of the standard servos and added the

price of the micro servos to the total. He also swapped the 8 channel receiver with the lighter micro 535 (I also had them swap the 650mAh receiver battery pack with a 270mAh one)! They have great prices and are very flexible. I'll be receiving the flight system in a couple of days. This beats the heck out of being forced to buy servos etc., that I may never use. You might want to pass this on to fellow electric flight enthusiasts.

As always, thanks for the info.,

Jim Yuzwalk

Another Source for Hitec E-radios is SR Batteries

from SR Late breaking news sheet

At Last! A radio system for the Electric and Soaring R/C flyer at an affordable price!

We've teamed up the Hitec RCD to bring you a micro radio system that only includes the items you really need. Not those you don't. The system includes the Flash5 transmitter, Micro 535 five channel receiver, two HS-80 Micro servos with accessories, a system charger, switch harness and aileron extension. You won't get a full size receiver, full size servos or a full size receiver battery pack. For the first time, the box will be empty when you install this new radio system in your new Electric aircraft or sailplane.

*2 Model Memory *Model Copy Function *Rudder/Aileron, Elevon, and V-Tail Mixing *Dual Rate Ailerons and Elevator *Digital Electronic Trims *End Point Adjustment *Total Volume Control *Servo reversing *Exponential Rates *Trim Memory and Reset *Timer and Low Battery Alarm *Trainer Function

The price? That's the best part, only \$199.95!

Also not that Larry's finally on line! SR is MORE THAN BATTERIES, they are a full line; motors, radios, planes, etc., supplier. SR's site is hosted on Steve Anthony's Hangtimes.Com site, you can go directly to SR at <http://www.hangtimes.com/vendor1.htm>

SR Batteries, Box 287, Bellport, NY 11712 516-286-0079 or email at: 74167.751@compuserve.com

Sponsor of the Mid-America Fun Flies

New Happenings at Bill Griggs's Models

Bill Griggs RR2 Box 64, Whitelaw Rd., Canastota, N.Y. 13032. Now accepts Credit Card orders call at (315) 697-8152. Visa, MasterCard, Discover and American Express.

NEW CATALOG AVAILABLE \$1 OR FREE WITH PURCHASE

By the time you read this, Bill's kits should be laser cut. He's carrying many more items, including several exciting planes designed by Don Belfort. He is also supplying batteries for S400 models, as well as the FMA receivers and servos. Send for his catalog or visit him on line at: <http://ourworld.compuserve.com/homepages/griggskill/>

News from the Gulf States Area

Mike Finnan email at: mikiefinnan@worldnet.att.net



Ken,

I thought you might want to see some of my electric planes. The first one is a Tom Hunt Mega-Watt as a low winger. It has an Astro 40 with a 3:1 MAT (Modelair-Tech) belt drive on 24 1700 SCRC cells. It weighs 8 lb.12 oz., has an 80 in. span and 1300 sq.in. of wing area. It also has flaps. It is covered in orange and white Monokote™. I call it GIGA-WATT...

It flies very well. With the flaps down it slows down to a crawl with no tip stalling. It loops tight from level flight and gets off in about 25 feet...Tom says the plans should be available by now.



The other picture is my design for the All-Up Last-down event. It has a 120 in. span and about 1100 sq.in. of wing area. It weighs about 4 lbs. (depending on batteries). It presently has a speed 600 12v motor on 4 6cell 1400AE packs through a series parallel switch (John McCulloch design) and a FX35D speed Controller (it keeps my receiver pack charged in flight + minute rpm adj).The prop is a 20x10 Rasa. I've gotten 45 minutes continous motor run so far, but I have to do better to beat the big guns.

I sure would like to see you in October at the Gulf States Fly-in.

Plane Ratins from Orville Shields

email: orville.shields@Central.Sun.COM

Ken,

I haven't been around for a while but I have flown a little. I thought I would add to the ratings if you would like.

So far this year I have flown a couple new planes.

Hobby Lobby PS 78, Astro 05G, 7x1500, 11x7 prop, 58oz. *** I like the looks and the way it glides but it will tip stall very easily. I think it could use a little more dihedral because it hunts

and it doesn't groove like I think it could.

Ted Davey (I think) Flybaby, included motor, 8x4 and 7x6, 7x1500, 43oz. no *'s We have tried to fly it twice and all I get is a fast, underpower landing. We may try to install another motor and try it again.

I have also been flying my Seniorita with a new set of RC2000 cells and I am very happy. I get about a 15 minute flight with a mixture of whatever I want as long as I practice a little power management.

One more thing, last night I charged 2 sets of batteries (3 7-cell packs at once) for the Astro Hog. I use an Astro 112D charger on a lawn tractor battery. During the 3rd set of batteries the lcd window on the charger went blank and the charger it self was very warm. I opened up the charger and found a burned up transistor (one of the power transistors that are heatsinked to the front panel). Have you heard of this happening? I will send it in but thought I would ask if anyone knows what I did wrong.

Love the Seniorita,
Orville

(According to what I've heard, Astro Flight Chargers will continue to try and draw from a low source battery and something usually gives. My "guess" is that it was a low source battery that was your problem. Charging 3 physical packs that are

identical in amp hours and manufacturer should not have been the problem. Many people use 3 physical packs to make up a 21 cell pack, etc. Since they were run as a 7 cell pack and 14 cell pack, I assume from you saying they were 2 sets, they probably weren't discharged exactly the same, but I still believe the problem was the low voltage on the source battery. What do you all think? km)

Central Indiana Electric Fly-in

Ralph Weaver, CD, and the Madison County RC Flyers put on their first electric fly-in on May 24 near Franton, IN. I'm not sure how Ralph did it, but he managed the best weather of the new flying season. It was a bright sunny day with low winds. Perfect! (Unfortunately, the next two days didn't prove as good for the folks trying to run the Indy 500!)



Don Belfort selects one of the planes from his Air Force. Yep, that Bigger one is his. Remember, he doesn't just fly the "small" ones!

Ralph and the MCRCF are to be congratulated on a well run and well attended meet. Besides all of the "open" flying, there was a Speed 400 race, LMR for Speed 400, Class A, and Class B, and an All Up, Last Down. Lots of action for everyone.



There was a lot of action going on all the time. No "Hanger Queens" were noted here!

Ralph and his workers provided great transmitter impound support, as well as running a well stocked concession stand! All of the hard work in organizing and running this meet paid off in a well received day.

My day started at 5:00 A.M. with the drive down. I arrived in plenty of time to hook up with Dave Grife, Clay Howe and Keith Shaw before the meet "officially" began



Note the difference between this version of Keith Shaw's M35b and the version shown in the July issue, which was the M35a. The Stearman hides under it's protective cloth, while the King Crimson is in the background.

The day ended with the passing out of the awards and the donations from great manufacturer support. There were lots of goodies for everyone. Even though I didn't get one of the "biggies", I was really happy with the set of Dimwatt plans and the New Creations catalog. I really need a new catalog!

Great day. Hopefully they will do it again next year, and we'll see you there.

For those of you who can get to the Internet, I've put a slide show of this day in the on-line version of this issue. To view the slide show, visit

<http://members.aol.com/ampaug97.htm>

Dave Grife's 27% Extra

At the Madison County R/C Electric Fly In, Dave Grife gave me the following info on his 27% Extra 300S.

It is based on Midwest Plans. He redrew the fuselage to use a truss structure, mostly 1/4" square balsa with some spruce longerons. The turtle deck is 1/64" ply, as well as the wing doubler area inside the fuselage. He used the Midwest airfoil, except he sheeted with 1/16" balsa. The tail is truss sticks.

Power is the Sport Astro Flight geared 60 with the standard gearing. He uses 33 Sanyo RC2000's. The prop is an 18x8-14 turning at 5700 RPM. The controller is an Astro Flight 204. The static amp draw is 27 amps. While

the aerobatic flight duration is 6.5 minutes.

It has Dave Brown 3" lite wheels, a R/C America composite landing gear, FiberGlass Master cowl and wheel pants and Midwest canopy.

It weighs 13 pounds. He noted that he's going to be adding a high torque servo to the rudder. There's been no problem so far, but he just wants to be safe.



For more information on this great plane you can send mail to Dave at:

Dave Grife
471 Morse St.
Coldwater, MI 49036

Please Note: I received the following information and I am passing it on to you. km

Fellow Electric Flyer,

I've just authored a new 96 page book entitled PROP TALK. In the book, in a dialogue between two modelers, I've discussed simply how model aircraft propellers

work and how to predict propeller performance based on diameter, design, RPM, and air density. The dialogue explores propeller performance for commonly used propeller designs, the results of seven specific experiments with propellers, and the application of these experimental results to understanding and improving electric powered flight system performance. I've included in PROP TALK the description of a method to select a propeller best matching the power system motor/gear box/battery combination to provide an optimum balance of launch or takeoff thrust and flight duration for an electric powered sailplane or sport model.

An appendix of the book lists the static thrust coefficients for over 220 commonly used and readily available folding and fixed blade propellers. This greatly extends the list of thrust coefficients available on the Field Thrust Calculator for Electric Flyers. The book also includes the January 1997 revision of the Field Thrust Calculator for Electric Flyers, a mechanical, hand-sized chart calculator. This simple chart calculator, designed using nomographs, allows the user to perform calculations of a power function, air density, and finally static thrust based on a knowledge of propeller RPM, propeller design/diameter, air temperature, and field elevation. The static thrust coefficients can be used in conjunction with the Field Thrust Calculator to calculate static thrust for elevations from sea level to 7000 feet and for temperatures from 0 to 100 degrees Fahrenheit.

There are graphs of the static thrust coefficient versus pitch in the book for eight fixed blade propeller designs of various diameters from 7 to 14 inches. These graphs show how the static thrust coefficient changes with increasing pitch as each design begins to exhibit the onset of stall in the static test condition. Information presented is based on experimental measurements.

Available direct only from ARPI, 900 Bower Drive, Idaho Falls, Idaho 83404 - Price (check or money order only) \$17.95 plus \$2.50 shipping/handling. Good flying!
Best Regards, Donald W. Brooks

From the Electric Model Flyer - Newsletter of the EMFSO

Now Edited by:

Al MacDonald

5-2881 Lawrence Ave. E.

Scarborough, Ontario, Canada M1P 2S8

almac@octonline.com

**Building a Simple On/Off Switch
by Tracy Narine**

I have been attempting to build on/off switches for my electric airplanes for a while now. Although I am handy with a soldering iron, my electronic circuits usually lack robustness. I would get to the flying field and something would break. I was always looking for a way to make my circuits more robust.

I had been experimenting with a circuit from Radio Control Models and Electronics (January 1996 issue) that used a logic level FET (BUKS55-60A/B) to turn a 5V relay on and off. The 5V relays I bought are rated at 10 amps and I got them from Active Surplus on Queen Street in Toronto. The cost of the relay was \$2.00.

One day I had the idea that if the logic level FET could

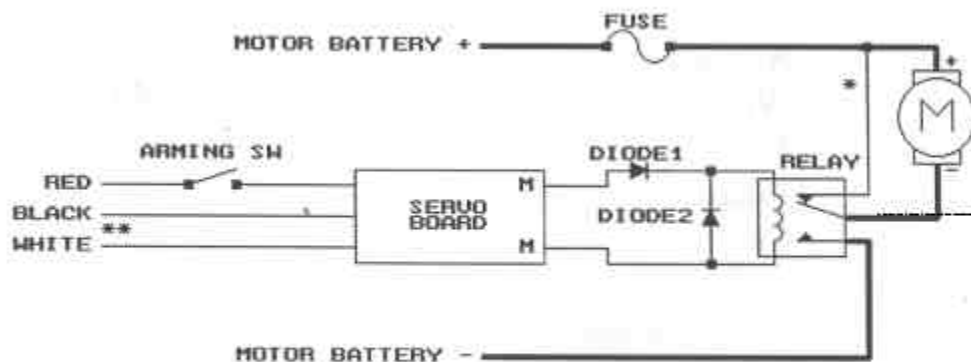

* OMIT THIS CONNECTION IF YOU DON'T WANT A BRAKE.
 ** FOR JR, BLACK LEAD IS BROWN, WHITE LEAD IS ORANGE.

turn the 5V relay on, then a 4.8V servo circuit could probably also turn this relay on. I had seen other on/off switches where the relay voltage required to turn it on was much less than what was specified. What could be more robust than the circuitry in an existing servo? Not knowing how to build this switch, I bounced the idea off my friend Stefan Vorkoetter, who came back with the following circuit: (Pictured Above)

All you need is a servo, two diodes, and the relay. A regular size servo will do since there is little advantage to using a micro for this circuit. As electric flyers we all have a few regular size servos hanging around! Remove the electronics from the servo, giving you a circuit board that has the servo leads, the motor, and a potentiometer connected to it. Remove the motor by cutting its wire leads close to the motor. This should give ample wire length for building the circuit. (If you are using a servo with the motor soldered directly to the board, such as a JR 507, unsolder the motor and solder some hookup wire to the pads where the motor was connected.) Now wire it up as illustrated above (the points marked M are where the motor was attached).

Plug the servo circuit back into the receiver. With the stick pushed all the way up, the relay should be on. With the stick at the other extreme, it should be off. If the operation is backwards from what you intended, just reverse the connections to the M terminals. When the stick is near the middle of the travel, the relay might chatter, so you'll want to move the stick quickly from end to end. You can adjust the turn-on point by adjusting the servo's feedback potentiometer.

Here is how it works. When the stick is at one extreme, the servo will sense that it needs to move the nonexistent motor one way. It will make one M terminal (say the top one) positive, and the other one negative. So, current will flow through Diode 1 and energize the relay. When the stick is at the other extreme, it will reverse

the polarity of the M terminals. Now Diode 1 will block the current from flowing, so the relay will be off. The only problem is when the stick is toward the on-side, but near the middle. The current will be pulsed at 50Hz, and at some point it will be enough to make the relay chatter but not to turn it on. This pulsing is done so that the servo motor begins to slow down as it reaches its desired position.

The servo's output driver transistors are easily able to handle the current requirements of

just about any relay. After all, a heavily loaded servo can easily draw more than 1 Amp without burning out. Diode 2 is used to prevent back EMF from destroying the output drivers.

I used 1N4001's for the diodes in this circuit, although any small diode will do (e.g., 1N914 or 1N4148). I built the controller on a piece of circuit board that was pre-drilled and has copper traces already on it. Remember to add extra solder to the traces (positive and negative) that connect to the motor. If not, the traces will burn out at high currents. Alternatively, run the motor wiring directly to the relay terminals. Also, make sure that when you set up the controller, that the motor is off when the relay has no power. This way, an arming switch need only cut power to the servo/relay circuit to turn off the motor.

The relay I used was SPDT so it has Normally Open and Normally Closed terminals, which you can take advantage of to provide a brake as illustrated.

I have used this controller in a Speed 400 glider and did ground testing with an AP29 motor. I have not had any problems with it so far. Also note that this circuit could be modified to power other electric devices such as lights.

The June EFO Meeting

The June EFO meeting was held at Ken's house. There were a number of things discussed including a "possible problem" Jack Lemon has found with Sanyo 1700SCRC batteries and their ability to hold their capacity over time. Jack is going to talk to Keith about this, and I'll let you know more about it when we learn more. Have any of you noticed diminished capacity with Sanyo 1700's over time? **Remember this is not a finding** - we are just looking into it - DON'T PASS THIS ON AS SOME KIND OF RUMOR. We just want to know why Jack's numbers came out like they did.

Upcoming Events:

Aug. 2 - 5 - AMA Headquarters, Muncie, IN Doug Ward, R.D. #1, Box 189. Irwin, PA 15642 (412) 446-5891
DWard79207@aol.com

Aug. 16/17 Halton Hills, George Ball Memorial Electric Fun Fly, Ont. Geoff Miller (905) 454-5198

September 20 & 21 Queen City Airport, Allentown, PA: KRC - setup on the 19th. For more info e-mail Anthony Assetto at 102723.2566@compuserve.com

October 4 & 5 11th Annual DEAF Fly-In, Dallas R/C Club Field in Seagoville Greg Judy (817) 468-0962 email 75267.224@compuserve.com

June Meeting (cont.)

Since June was the 40th anniversary of the *Radio Queen*, the first recorded successful electric R/C plane, Ken shared some information about this aircraft featured in Ian Peacock's book Introduction to Electric Flight. According to the book, the first recorded successful R/C electric flight was on June 30, 1957. It was built and flown by Col. H.J. Taplin and had a government surplus Emerson motor and Venner silver-zinc accumulators for power. It used a "bang-bang" clockwork escapment for rudder control. The picture is from the book.

Ken also showed an easy way to test whether a "can" motor has neutral or advanced timing. A new Astro Flight Super Box was added to Richard Utkan's AF40G, with the pinion removal and replacing being demonstrated and participated in by the members.

Ken also showed off his new MaxCim with hydraheaded controller plugs. (Think about that one!)

Good meeting.



The Ampeer
Ken Myers
1911 Bradshaw Ct.
Walled Lake, MI 48390

**Next Meeting: Thursday, August 7, 1997,
Time: 7:30 or ASAP
The Rushton Road Flying field, South Lyon, MI
Located between 9 Mi. & 8 Mi. , east side of
Rushton Rd.**