

The Officers:

<b>President:</b> Ken Myers 1911 Bradshaw Ct. Walled Lake, MI 48390 phone: (810) 669-8124	<b>Vice-President:</b> Richard Utkan 240 Cabinet Milford, MI 48381 phone: (810) 685-1705	<b>Secretary/Treasurer:</b> Debbie McNeely 4733 Crows Nest Ct. Brighton, MI 48116 phone: (810) 220-2297
<b>Board of Directors:</b> Keith Clark 2140 E. Highland Rd. Howell, MI 4848843 phone: (517) 546-2462	<b>Board of Directors:</b> Jeff Hauser 18200 Rosetta Eastpointe, MI 48021 phone: (810) 772-2499	<b>Ampeer Editor:</b> Ken Myers 1911 Bradshaw Ct. Walled Lake, MI 48390 phone: (810) 669-8124

**Ampeer subscriptions are \$10 a year U.S. & Canada and \$17 a year world wide.**

**The Next Meeting:**  
**Date: Thursday, Feb. 6 1997 Time: 7:30**  
**Dublin Community Center, just N. of the village of Union Lake on Union Lake Rd. across from St. Patrick's Church**

**Just View It!**

**CHVideo is happy to announce a Post-Holiday Sale on all of our Electric Flight Videos.**



Videos available are:

- '94 KRC - 1 hour 47 minutes - VHS SP
- '95 KRC/Mid America - 1 hour 50 minutes - VHS SP
- '96 Mid America -

- 1 hour 37 minutes - VHS SP
- '96 AMA/NEAC Electric NATS - 2 hours 25 minutes - VHS SP - T-160

**Sale prices are as follows:**

- 1 video - \$18    •2 videos - \$32
- 3 videos - \$42    •All 4 - \$50

...the prices above include shipping to addresses in the US and Canada, including APO and FPO.

Videos may be ordered by sending a check or money order to:

CHVideo  
310 S Jefferson St  
Sturgis, MI 49091

**NOTE:** Make check or money order payable to: Clay Howe  
This Post-Holiday Sale will remain in effect until at least January 31, 1997. Please mention in your order where you saw the sale notice...

For more information, e-mail:  
clayhowe@net-link.net  
clayhowe@juno.com

**KRC Videos**

1994 and 1996 KRC videos may be purchased from: (the 1994 is not the same as Clay's)

Real-Tour Productions  
Box 466  
Perkasie, PA 19944  
Tel.: (800) 958-4336  
Price is \$23US a piece, which includes shipping for each VHS tape

# Ampeer

**What's in this issue?**

**View It - New Props - Small Stuff - More on SR Techniques - Lazy Bee Review - Choosing the Right Prop - Some plane ratings - Motor Mount Source - ModelAir-Tech H-100 Belt Drive**

Keep an eye out for SR Batteries to announce tapes of the '96 Symposium.

### Prop News

Did you ever notice how easy it is to miss product notices that might have an affect on us. In case you missed this press release, here it is from *Model*



*Aviation* -

**Master Airscrew G/F Series Propellers in new sizes from Windsor Propeller Co., 3219 Monier Cir., Rancho Cordova, CA 95742 - tel. 1-(916) 631-8385 or fax 1-(916) 631-8386).**

The four new sizes are 7 x 5, 8 x 5, 9 x 7, and 10 x 5. Designed with Windsor's state-of-the-art CNC tooling, these props have NASA airfoils, true helical pitch, and accurate balance. The new sizes remain true to the original G/F Series design in appearance, but they have improved performance with **more thrust at lower RPM**. More sizes will be coming out in new and replacement pitches and diameters. For a free catalog, send a pre-addressed and stamped envelope to the company.

### Aint that interesting?

*Model Airplane News* had the same press release in its January issue but stated there are 11 new sizes: 7x5, 8x5, 8x7, 9x7, 10x4, 10x5, 10x9, 11x4, 11x5, 11x8 and 11x9.

### Small Stuff

from the November 1996 issue of:

*Silents Please*

the newsletter of the Silent Electric Flyers of Long Island edited by: Fred H. Dippel, 2 David Ct., Glen Cove, NY 11542

At various times in the past I have given some favorable opinions about small electric free-flight models. It occurred to me the other day that, whereas, in contrast to rubber-powered models, they weigh more, so hit harder and break more readily. They are more like full scale aircraft in that respect. The ratio of power plant weight to airframe weight is more like that of full scale aircraft, also, and the weight distribution is more similar, thus, so are the trimming requirements and so are the flight characteristics.

Therefore, small electric free-flight scale would seem a natural combination, no? Of course! You should see some of the great scale models at the FAC events! Remember Don Brull's Dornier Do X? But it is not a venture to be rushed into.

My strategy is to learn rubber-power skills by flying models of comparable size and weight starting with sport models, such as Bostonians, eventually going on to rubber-powered scale, such as peanut and dime. Then, learn E-power by flying the sport types; that's where I am now, I think. Then, move on to E-power in small scale types. After that, I'm not sure, but think of the possibilities. I think there's a Grumann Widgeon in-my future. Or, maybe for indoors, one of those Curtiss pre-WWI single-place biplane flying boats. Then; eventually, maybe a Blom and Voss BV-238, which would have to be RC, of course, because it had six engines. (Yes! You did read that correctly. I am confident that my RC flying ability will be up to the job by that time.) After that, the sky's the limit!

This is not a completely nutty-idea.- According to September DEAF Notes, the newsletter of a highly respected electric RC club in Texas, they have planned their second annual indoor fun-fly, so it has some appeal in other parts of the country, too. Now, just in case you're interested and want to know some sources of scale kits, here is a partial list (these are rubber-powered, of course):

America's Hobby Center  
146 W. 22nd St.  
New York NY 10011-2466  
1 800 989 3989

Dare Hobby Distributors  
Tom's Patchogue Hobby Center  
240 Hedford Ave.  
516 475 8856

Diels Engineering, Inc.  
P. O. Box 263  
Woodville OH 44001

Gene Dubois  
P. O. Box 30053  
Acushnet MA 02743

Easy Built Models, Ltd.  
Box 425  
Lockport NY 14095-0425  
716 438 0545

Golden Age Reproductions  
P. O. Box 1685  
Andover MA 01810

(cont. on next page)

Herr Engineering Corp.  
1431 Chaffee Dr., Suite 3  
Titusville FL 32780  
407 264 2488

Hiline  
P. O. Box 11588  
Goldsboro NC 27532

Hobby Lobby International, Inc.  
5614 Franklin Pike Circle  
Brentwood TN 37027  
615 373 1444

Peck-Polymers  
P. O. Box 710399-MB  
Santee CA 92072-0399

Penn Valley Hobby Center  
837 West Main St.  
Lansdale PA 19446  
215 855 1268

ScienText, Inc.  
48 Whitney St.  
Westport CT 06880-3753  
203 221 1326

#### More on SR Techniques

SR BATTERIES, INC., BOX 287 BELLPORT, NEW YORK 11713 FAX 516-286-0901 PHONE 516-286-0079

*(Last month the Ampeer contained a listing of what was available in past issues of this journal. Here's more info about it. You've got to check this out. Very helpful. km)*

Techniques is a new concept in modeling. It isn't a magazine, or a book. Instead, Techniques is an archive of modeling knowledge and expertise. In Techniques you'll find some of the most respected modelers in the country sharing their personal modeling tips and techniques.

Each volume of Techniques pinpoints a specific modeling task or problem and draws on our eight Contributors' 300+ years of modeling experience for solutions that work. With Techniques, you can easily build your own personal modeling library tailored to your personal needs. Techniques' contributors include Steve Anthony (Electric Conversions), Larry Davidson (Old Timers), Bob Hunt (Airframe), Dean Pappas (Flight and Aerobatics), Tim Renaud (Soaring), Larry Sribnick (Electric Flight), Paul Tradelius (Helicopters), and Don Typond (Finishing).

The basic idea behind Techniques is that after reading a

volume, you should be able to do something you weren't able to do before reading that particular volume. It's that simple. The writing style used in Techniques will give you the feeling that you're visiting a Master modeler's shop and looking over his shoulder while he works. Each volume is so jam-packed with information that if a paragraph were left out, you'd be missing something. No fluff, no bull, just pure "how to" information. If you'd like to be a better builder, finisher, or flyer, Techniques is for you. And, the best part is that each volume of Techniques is only \$2 plus 50 cents for First Class mailing to your door.

There are two different editions of Techniques and you can subscribe to either or both of them. R/C Techniques covers the entire R/C field including Sport, Trainers, Pattern, Scale, Giant Scale, and Old Timers. You'll find information on building, materials, adhesives, proper radio installation, covering and finishing. In addition, R/C Techniques covers the trimming and flying of all kinds of aircraft from Trainers to Pattern ships. ARF's are included, too.

The second edition of Techniques, Electric Flight Techniques, gives you everything you've ever wanted to know about Electric Flight from the spinner to the battery pack. All of the tips and techniques that usually take years of trial and error to discover are included. If you'd like to do it right the first time and get the most out of Electric Flight, Electric Flight Techniques is for you.

In addition to the bi-monthly R/C Techniques and Electric Flight Techniques, we also have Heli Techniques and Sourcing Techniques. These editions of Techniques aren't available on a subscription basis yet, but they are growing in our archive and modelers should check in with us periodically to catch up on the new additions in these areas. Eventually, we plan to have each of these editions available on a bi-monthly basis, too.

Each volume of Techniques is typically four pages in length and a full 8.5" x 11" in size. We even three hole punch each volume to make it easier for you to build your own custom modeling reference library.

What makes Techniques so unique is that once a volume comes out, it doesn't disappear. Instead, it is simply added to the list of volumes available. In this way you don't miss a thing. The list of information just grows and grows. At anytime you can order the information you want without paying for the information you don't want. And the best part is that Techniques is only \$2.00 per volume plus 50 cents First Class postage and handling per order. Order as many volumes as you'd like for only \$2.00 each!

If you'd rather subscribe to Techniques for the year so that you get each new volume as it comes out rather than trying to remember to order them periodically, it's no

problem. R/C Techniques is published on the even months of the year, February, April, June, August, October, and December. Electric Flight Techniques is published on the odd months of the year, January, March, May, July, September, and November. A calendar year's subscription to six volumes of either R/C Techniques or Electric Flight Techniques would be \$15 including First Class Postage. If you'd like to subscribe to both editions, a total of all 12 volumes, the cost would be \$30 including First Class Postage for the year. If you subscribe to Techniques at some mid point in the year, you'll receive all of the volumes which have already been published for the current calendar year up to that point.

#### Here's who's writing for Techniques...

**Larry Sribnick**, Electric Flight - Larry is the President of SR Batteries. He has been a modeler for 45 years and has been involved in almost every aspect of the Hobby including Sport, Pattern, Soaring, Slope Soaring, Giant Scale, Helicopters, Old Timers, and Pylon Racing. He is a full scale Instrument Rated pilot and he was the CD for the 1995 AMA Electric Nats. Larry is the founder of the National Electric Aircraft Council and he has been a member of both the AMA Electric Contest Board and the FAI Electric Selection Committee. Larry has written for R/C Modeler and Flying Models magazines and he has been the Electric Flight Columnist for Flying Models magazine. He has also written for Popular Photography, Camera 35, Photographic, Sail, and Canoe magazines. Finally, Larry is the creator of the SR Electric Flight Symposium, Electric Night Fly, and Electric Indoor Fly held each year in conjunction with the KRC Electric Fly In.

**Bob Hunt**, Airframe - Bob has been a modeler for 45 years. Until recently he was the Editor of Flying Models magazine and although he is an accomplished R/C builder and pilot, Control Line Stunt flying is his specialty. In fact, he has won both the US National and World Champion titles in the event. Bob was recently inducted into the Precision Aerobatics Model Pilots Association Hall of Fame. Bob is known for his technical achievements in innovative construction techniques including the "Lost Foam" process and triple internally cored foam wings. He has written many articles and columns over the years and he has published many original designs. Bob is presently President of Robin's View Productions and we're hoping to have him help with the planning and production of a series of Techniques videos.

**Tim Renaud**, Soaring - Tim is the General Manager at Airtronics where he is responsible for the development of

new aircraft designs and soaring related accessories and radio systems. A modeler for 24 years, Tim was the driving force behind the Airtronics Vision radio system. Although he is primarily interested in Thermal Duration soaring, Tim has been very active in both Scale and Slope soaring as well as Sport and Old Timer Electrics. Tim is heavily involved with F3B Soaring Competition and he attended the '91, '93, and '95 World Soaring Championships as a U.S. Team caller. In '97 Tim is the Manager of the U.S. F3B Soaring Team. Tim collaborated with his dad, Lee Renaud, on the Aquila Grande, Sagitta 600, 900, and XT, and the Olympic 650 designs as well as his own Cumic, Cumic Plus, Eclipse, Legend, Legend SC, Whisper, Whisper 95, Peregrine and Sapphire sailplane designs. Over the years Tim has written for R/C Modeler, Model Builder, and Model Airplane News magazines.

**Don Typond**, Finishing - A modeler for over 50 years, Don is the former Editor of Model Airplane News, Air Progress, and Private Pilot magazines. Over the years he has been involved in Free Flight, Waketield, Coupe, Towline and HL Gliders as well as indoor and outdoor Rubber Scale, Control Line Stunt, Speed, Scale, and R/C Sport and Scale. Don is a member of the AMA's Scale Contest Board. He is a full scale pilot with Landplane, Seaplane, and Glider ratings. Don has published articles and original designs in Model Airplane News, Model Builder and Flying Models magazines as well as having written for Flying and Sports Cars Illustrated magazines.

**Dean Pappas**, Flight and Aerobatics - Dean is an Electrical Engineer and he has been a modeler for 32 years. If it has wings, Dean has flown it, but he is particularly interested in Pattern and Aerobatics. He was the NSRCA District Champion in 1985-1988 and 1995-1996. He has also been a Top Ten Finalist at many AMA Nationals and FAI Team Trials and he has competed at the TOC and Top Gun events. Dean is a member of the AMA's F3A Team Selection Committee and he judges and conducts modeling seminars all around the country. For the last 13 years he has written a column and many feature articles for Flying Models magazine.

**Steve Anthony**, Electric Conversions - Steve is in charge of Customer Services at SR Batteries. He has been a modeler for 35 years and is particularly interested in Electric Soaring and Sport Scale conversions of wet designs to Electric power. Steve was the Asst. CD at the '95 AMA Electric Nate and he placed 2nd in both Class A and Class B Sailplane at the '92 AMA Electric Nate. In addition, Steve has designed several very successful Electric Sailplanes and

he is a staff member on Compuserve's Flight Simulations Forum where he specializes in head to head military air combat. Prior to coming to SR, Steve was a specialist in composite materials and electronics in the Marine Industry.

**Paul Tradelius**, Helicopter - Paul is a pilot for USAir and he has been a modeler for 45 years. Before retiring, Paul was a Lieutenant Colonel in the Air Force where he flew the F-4 Phantom and was the Chief Acceptance test Pilot who flew each new F-16 before it was accepted by the Air Force. Although he has flown all kinds of model aircraft, Helicopters are Paul's specialty. He has written articles and columns for many of the modeling magazines and he wrote *The Basics of Radio Control Helicopters* which is now in its second edition.

**Larry Davidson**, Old Timers - Larry has been a modeler for over 45 years. Although his current passion is SAM Old Timer Free Flight, he has been active in R/C, Control Line, Free Flight Power and Rubber, Soaring, and Helicopters. Larry was the SAM R/C Assist Grand Champion in 1991, 1992, and 1993. No one else has been Grand Champion three times in a row. In addition, Larry has won many "Best Finish" and Spirit of SAM Concourse awards. Larry is a Private Pilot and he has his Instrument Rating. Around Long Island, Larry is known for his Hobby Shop which over the years became the best in the area. In 1986, Larry sold the shop so that he could devote his full time to Old Timer competition.

### The Bee Stings

from the September issue of:

*DEAF Notes* the newsletter of the Dallas Electric Aircraft Fliers

edited by: Frank Korman, 9354 Forest Hills, Dallas, TX  
75218-3633 - phone (214) 327-8411 or e-mail:  
FranKorman@dcccd.edu

*(Thought you might enjoy this one. These are very popular planes. It was a real pleasure to get to meet Frank at the '96 E-Nats in Muncie, and read his article about the Nats in Model Aviation. Great Job Frank! km)*

Clancy Aviation's Lazy Bee has become an instant classic it seems. Swarms of the buzzy beggars seem to be everywhere in sizes from peanut to giant scale; with or without floats; highwing or midwing, etc. Safe to say this plane's pizzazz is of a whimsical nature. So if you're silly putty in the wings of a cutie read on.

The Bee comes in a box bedizened with a lazy bee reclining in a hammock while he or she wiggles the sticks on a transmitter.

And speaking of sticks that's what there is an abundance of inside the box along with ribs (only 9 in the 48" version 1 built), a few formers, some 1/16 sheet, and assorted other pieces. This is old timer construction in a new form.

The building instructions are nicely done with good drawings and suggestions placed appropriately. This may not be a beginner's project, but it is not difficult to build. The wing goes together quickly with the rounded (about as big as a pie plate) 10" tips setting two inches dihedral off the the flat center section.

The tips are laminated around a form that the modeler provides using a template in the kit. The 1/16 thick wood for the tips is about 27" long which gives you an idea of how wide (about 12" at the root) the tips are. I built the wing to spec except for adding 1/16 by 1/2 strips top and bottom at the juncture of the center and tip sections. This was done to make it easier to adhere the covering to the center and tip sections. A key and bolt wing hold down is shown as an option. I used the rubber band approach as it seems appropriate to this ship.

The fuselage is built up using traditional old time stick techniques. I followed the plans adding a suggested side access door for the motor battery, and made up a detachable motor mount/holddown so I could easily try out different motors. The porthole windows are cut out for you. Clear mylar is provided for the windows.

The tail feathers are built up with laminated edges for which template patterns are provided. The rudder is of the all flying variety (i.e. it is all rudder with no fin). There is a stab and elevator. A steerable tail wheel is used.

Trexler balloon tires are not mandatory, but they sure increase the little toot cuteness factor. Using these is a first for me, and I have found a "pump" in the form of a bulb that might be used to clean out one's ears. You're advised not to inflate the tires with your breath as the moisture eventually rots the tires. *(and makes the filler tube stick together! oops km)* Rubber band shock absorbers are used, but an option using RC car shock absorbers is shown.

I covered my Bee with Airspan a verylight tissue/silk looking mylar that requires adhesive be brushed to the plane's surfaces. The stuff goes on fairly easy, although "doping" the sticks gets old. I like the visibility of the hot lime and hot red colors. I don't like how it is relatively easy to puncture. Airspan weighs about 3 grams a square foot (without the dope). It sure looks good on the Bee. Templates are provided for wing and fuselage scalloped trim (which I did not do).

My Lazy Bee weighs about 40 to 43 ounces depending on the battery, motor, and prop. Wing area is about 630 sqs. giving a loading of about 10 oz./sq.ft.. I've used a can motor on a 3:1 box with a Master Air Screw 12x8 folder;

the same prop and gearbox with a Speed 500; a Kyosho LeMans 360PT with a 2.5 gearbox and a variety of props; and an Astro 5 turn geared 2.38:1. Six and seven cell packs have been used. The best combo for endurance and performance is the can motor (about 125 watts in on 7 cells) with the MAS 12x8 and 3:1 gear box. Be sure to either keep the folding prop from folding or use a fixed prop as a folding folder will hang up on the fuse. I'm using an Astro 211 contrulier and it works fine. The plane is very easy to fly. I've been handlaunching because of prop drag if ROG'd. It certainly will ROG. It will thermal. It's is the easiest plane (with wheels) to land that I've ever flown. Be sure to use low rates on the elevator and rudder. It takes very little movement to boot the Bee about.

In sum the Lazy Bee is a good quality kit that returns lots of sporty airtime and attracts lots of approving attention. Build yours and join me at the field so we can buzz up a storm.

### Choosing the Right Prop

*(The following two letters appeared in the November issue of Peak Charge, the newsletter of the Silent Electric Flyers of San Diego, edited by Steve Belknap LetIFly@aol.com They are presented here for there informational value on selecting "the right prop". km)*

#### The "'Tale' of two Models" - grows a little longer

Bob Benjamin responds to Lynn Heffern's article in last month's issue

The "Tale of Two Models" article in the November "Peak Charge" caught my attention to the extent that I feel the need to offer some input. I don't know John or Lynn personally, and have no idea as to their level of experience, and so have to hope that they will excuse me if I appear to presume to be telling them things they already know.

What I am going to say is based on a lot of experience with the sort of airplanes and power systems under discussion. My first thought is, "Why did they use the Astro 25; this is much more motor and battery than that little airplane needs". It becomes clear as I read through the article that the model under discussion is the Sportster 20, which has a wing area on the order of 400 sq. in., and for which a .20- .25 sixe glow engine is called out by the manufacturer. Perhaps it was assumed that the Astro 25 with an appropriate battery delivers power on the order of that of those engines. My experience has been that a good 25 installation is more nearly equivalent to a four stroke 45. That power would be OK, except that, as we know, with electric power we can't use a "larger motor" without also using the larger battery that goes with it. The Astro 25,

whether direct or geared, is far too much for the Sportster 20. The experience that John and Lynn relate appears to favor the direct drive installation. I would submit that what they are seeing is in fact the result of that installation's being lighter; and hence allowing a wing loading that is less in excess of what it should be than was the case with the geared motor.

The second factor that appears to me to be "out of whack" is the propeller selection. I don't have much experience with the Astro 25 in direct drive, but the 11 x 5 mentioned for the geared installation is probably far too little propeller for anything but a very lightly loaded airplane intended for duration above all else. My friends and I have flown geared sport-wind Astro 25s for years in airplanes ranging from Senioritas to Schneider Sports; the best props we have used are the Master Airscrew Electric Series 12 x 8 and 13 x 8. These will load the motor to about 28-30 Amps full throttle static. Empirical data indicates that the degree to which these undercambered props unload in flight is proportionally greater than "gas" props, such as Rev-Up and Zinger designs. If the 11 x 5 propeller didn't load the motor to at least 25 Amps, which I strongly suspect to have been the case, then the Sportster was carrying the weight of the 25 system with the benefit of only part of its power!

So, what will work? My baseline for a suggestion in my Tigerkitten, which at 450 sq. in. area is slightly bigger than the Sportster 20. I have flown Kittens on a geared Astro 05 and 7 cells at about 54 ox.. With this power the airplane is docile but underpowered. The power system I will recommend for the Sportster 20 is the same as what I suggest for the Kitten. First choice is the Model Electronics Corp. Turbo 10 Plus with their 6:1 gearbox, 10 1700 mAh cells, and a Master Airscrew 12 x 10 propeller. My three Kittens using this system weigh in at between 64 and 70 oz, these figures yield wing loadings between 20.5 and 22.5 oz. per sq. ft. and the airplanes are docile at low speed. Durations are five minutes plus, and power is sufficient for good vertical performance (like easy square loops from level, inside loops 100 ft. high, etc.). Level cruise is easy at well below half power. I'm also flying a Kitten on floats with this set-up - effortless takeoffs and good aerobatics, etc..

My second choice would be a sport-wind geared Astro Cobalt 05 on 9 cells (Yes, you can do this without hurting the motor as long as it gets good air flow and you use full power only for short bursts; that is, throttle back between maneuvers). Best propeller here would be the M.A. Electric 11 x 9. Third choice would be the Astro 15 on 12 cells; again, these are the 1700s and the propeller is the 11 x 9. I have flown Kittens at up to 4 3/4 lb. with no problem as long as the balance and trim are correct. This should pretty well bracket the range a Sportster 20 conversion might fall

into.

I strongly suspect that a Sportster using the Turbo 10/10 cell combination and built carefully, using a light covering such as silk or one of the films, would come in at around 3 1/2 pounds and be capable of serious vertical performance. Our experience at MEC with these motor systems in little models is that as the area drops toward the 300 - 350 sq. in. range, as long as the trim and balance are kept under control, model performance accelerates toward the unbelievable. We have chased hot 40 glow powered models out of the sky with 3 1/2 lb. foam fighters at about 325 sq. in. area with these systems. The temptation will be to use less propeller Don't do it, 12 x 8 or 12 x 10 M.A. Electrics are the way to go!

I would suggest that the power formula that was shared a few years ago by Keith Shaw is an excellent place to start in working out a conversion. That is, we use INPUT POWER as a reference, basing the calculation on the assumption of 1.1 Volt per NiCd cell, and measuring current at full throttle static with the chosen propeller. Efficiency factors can be ignored, as all we are doing is generating numbers to place our project on a scale developed by using similar numbers/data points derived from many other models whose performance has subsequently become known to us. Assuming a reasonable wing loading and configuration/trim status that are appropriate for controlled flight, 50 Watts of input power per pound of aircraft weight will permit takeoff and safe flight. 60 Watts will permit basic aerobatics, 70 or more should permit advanced aerobatics. For instance, if we use the Astro 05 example: 9 cells ( $9 \times 1.1 = 9.9$ ) x 25 Amps = 247.5 input Watts. If we put this into a four pound plane, we get about 62 Watts per pound. In practice, we can easily get closer to 30 Amps static from this motor and probably shave a few ounces off the model, thereby hitting about 70-75 Watts per pound.

Lest we forget the Astro 25, I will share a few experiences with that motor. As I mentioned above, nearly all my experience with this motor has been with the geared version. I have personally flown two different versions of the Schneider Sport Electric, Dennis Weatherly's Cloud Dancer 40 conversion, several Senioritas, and a couple of Goldberg Anniversary Cubs on geared Astro 25s on various combinations of 14 to 16 cells and the 12 x 8 to 13 x 8 propeller range mentioned before. In all cases the airplanes were nicely aerobatic, would cruise at half power permitting 5 - 7 minute flights, had docile wing loadings, and in all cases were flown over long enough periods of time to insure that no damage was being done to the motors using the props described. All these airplanes, except the Cloud Dancer, have been flown very successfully on floats without changing any aspect of the motor-battery-propeller

combination. Also of interest is that the 1/6 scale (6-foot span) Porterfield that I took to the US Scale Masters Championships in 1990 used a geared Astro 25 on 16 cells. Other competitors who saw it flying while other (glow powered) models were in the air had no idea that it was electric.

Steve, I hope that this rambling discourse is of some interest and that if you choose to use it in the newsletter it will be received as an attempt to share experience in a constructive manner. I would be pleased to share further thoughts, answer questions, or what ever, if the interest is there.

I really want to thank both Bob Benjamin and Bob Boucher for their highly qualified and thoughtful contributions. As editor, this kind of feedback is what I live for! - Sincerely, Steve Belknap

**'PROP'er Set-up is Essential for the Sportster 20**  
Bob Boucher of Astro recommends the correct choice of propeller for the Sportster 20

I find that the article on the Great Planes Sportster 20 with the astro 25 is not very useful except to show what not to do. The major problem with both models was the choice of propeller. In my book I recommend a Rev Up 9x6 or and APC 9x6 on 14 cells. These props will draw between 25 and 30 amps static on the bench, the motor will put out 300 watts and the shaft speed should be about 11,500 RPM. The prop pitch speed will be  $11,500 \times 0.5 = 5750$  feet per minute or 65 MPH. For aerobatics like loops and rolls one needs a flight speed of 2.5 to 3 times stall speed. At a flight speed of two times stall speed one cannot loop. At three times stall speed the loops are round. For this motor-battery-prop combination stall speed needs to be no higher than 26 mph and should be closer to 21 mph. If the stall speed is above 33 mph the model will be always on the verge of stalling and the first mistake will be the last. A wing loading of 16 ounces per square foot will produce a stall speed of 20 mph with a Clark Y airfoil. A wing loading of 24 ounces per square foot will produce a stall speed of 25 mph. My guess is that the Sportster has a wing loading closer to 30 than 24.

By using a 9x4 prop the motor power drops to 190 watts from 300 watts and the pitch speed drops from 65 MPH to 47mph. If the wing loading was 24 ounces per square foot or more you are looking at a crash waiting to happen. My suggestion is to use a 9x6 prop and throttle back if you want slow flight. This way you have maneuvering power when you need it.

We recommend a 12x8 or 11x10 on the geared 25. An 11x5 Rev Up will only load the motor to about 15 amps or about half its potential. To make matters worse the Zinger



brand was chosen. These props are too thick for electric flight and are not very efficient for our use. At 7000 rpm on a 12x8 the pitch speed would be 4666 ft per minute or 53 mph. This would be too low for a heavy wing loading of 24 oz. per sq foot. an 11x10 would give a pitch speed of 5833 ft per minute or 66 mph.

My main conclusion is that the wrong props were the only thing wrong with either set up. Extending the wing span by six inches might be a good idea because the wing area is too small and the wing loading is too high. A trainer or sport model is much easier to fly at 18 ounces per square foot than at 30 ounces per sq ft.

All my best regards - Bob Boucher

### More Plane Ratings

from: Dave Segal  
Keystone RC Club  
76641.2074@compuserve.com

I would like to add some additional ratings based on my experience learning to fly with electric power planes.

1. Nitto Kitty (same as Cox Canario) \*\* 280 can motor, Benson ESC, stock prop, 5x425mah, It did fly, but was probably the lowest powered plane I ever saw.
2. Peck Prairie Bird \*\*\* Leisure 05, gear 2.5:1, HiTec ESC, 7x1000mah, 10x6 prop, A nice easy to fly plane, but duration too short for a trainer.
3. Amptique \*\*\*\*\* Leisure 05, gear 2.5:1, JETI30 ESC, 7x1000mah, 10x6 prop, 37oz., An absolute dream to fly. It floats on lift like a glider.
4. Windstar EP (ARF)\*\* 540 can motor, APT on/off, 7x1400mah, stock prop, 54oz. A lead sled. Slow climb and too fast glide due to excess weight. The covering is a horrible "linoleum" that is unshrinkable. Turned into a great flyer by converting to .10 glow power and recovering wing with Monokote.

*(Thanks Dave. The Amptique is highly recommended by everyone. You can get one from New Creations R/C. While it aint pretty, it has a loveliness all its own! km)*

### More on Motor Mounts

from John Williams  
qyefli@worldnet.att.net

*(In the January 1997 issue of R/C Reports, Greg Gimlick excellently covered motor mounts in his column - super job - get this one folks. John sent the following information to*

*both Greg and me. Put Greg's info and this together and you'll be a mounting expert. km)*

Dear Mr. Gimlick,

Congratulations on your new column for *R/C Report*. Your motor mount article was a good start, but in my opinion you left out one of the best, although least known. Joe Pasquito of 168 Gainsboro Rd., Lawrenceville, NJ 08648 sells 4 different mounts. The first series looks much like the Astro radial mount except it is aluminum, and has a slot cut on two sides so the Astro brush holders can slide in from the front. It also has a set screw, but they provide a SS hoseclamp to tighten down on the motor, a much better system. They have two sizes for the 05-15 and 25-40. They stick out about 1 5/8 inches from the firewall.

The second pair are brand new - I haven't seen them anywhere. They are beam mounts for the same two size motors. They are V-shaped between the beams with 4 beam attach points. Between the attach points is space for the provided SS hoseclamp. Neat!! The prices on all these mounts are a little high, but for low volume, high quality I guess it is to be expected, and in my opinion, worth it.

Regarding the Stitzler mount, in my opinion, the 25-40 size should be a little heavier gauge metal as it doesn't stand much abuse. Despite this I still use it on occasion. However I modify it some by widening one of his strap holes enough to take a special "aviation" Stainless Steel hoseclamp. This clamp is both narrower and lighter gauge stainless than a regular clamp - much superior for our use. It was available in three sizes that were perfect diameters for us. This system I feel is far superior to his two suggested attach methods. I formerly bought these clamps at Home Depot here in Sarasota, but they no longer carry them. I sent one of my last ones to Joe, who was interested. If any one finds a source, please let me know.

### Rate a Plane

From: John A. Williams  
qyefli@worldnet.att.net

Ken,

My personal favorite is still my Electrostroke with an Astro 15 direct drive with an Aeronaut 8-5 folder as I fly no wheels and land on grass (polo field :) I use 10 1700SCRs. Also I added 1/4 inch to width and depth of the fuselage to make things less crowded. I have tried 12 1700s and both 10 and 12 1000 mAHs, but the 10 1700s is my choice. This is my \*\*\*\*\* rating. The Electrostroke, after 8 rebuilds weighs 56.5 oz. with 10 1700 SCR's and the Astro 15G. The area is 340 sq. inches, for a wing loading of 23.9 oz. per sq. foot. At 3/4 throttle it flies like a well-behaved pattern plane.

I've had a dozen or more run of the mill models, but one



not written up too much is the Modeltech slope ME 109. I have wheels on this and with 12 2700s it goes like bloody-blue blazes. The weights and wing loadings will follow as my memory isn't good enough. This is a \*\*\*\* for aerobatic types. The ME 109 also has 340 squares, but weighs 73 oz. with 12 1700SCRs. The wing loading is a very high 30.1 oz. per sq. inch. It flies somewhere between a pylon racer and a pattern plane. We haven't found yet just how far we can slow it down. Naturally it lands pretty fast and this plane is not for everyone - but exciting, yes. Using Astro's chart for watts out, that gives 57 watts per lb. I don't know if Keith's rule of thumb is from power in or out. With an 05G and 7 cells it would be 45.7 watts per pound. The Electrostreak is 51 watts per lb. The opinion of our "experts" is to back off to an 11-7 prop as the 12-8 is too fast and too short.

The trouble with the rating system is that for a glider flyer it would be a \*-- a hold on and pray job. This has a Master 12-8 electric wood. The P 51 of this series has more wing area so it might be better. I have a kit unbuilt like a dozen others.

### More Ratings

From: Dave Harris  
dharris1@concentric.net

Ken... I would like to submit the following ratings:

**EZ Built Spacewalker** \*\*\*\* Astro Flight 10T cobalt 15G, 12 cells and 11 X 7 Master Airscrew electric wood prop. Steve Neu controller and 270 mah airborne pack. All up wt < 60 oz. Will perform consecutive outside loops from level flight. Realistic flying speed. Only downside was that the "EZ-Built" is sort of an oxy-moron. You have to like to and have experience "building". I only regret that radio problems did mine in.

**Modified Electro streak** \*\*\*\* Wingspan 52" foam w/balsa sheeting Fuse: No mods Separate micro servos for ailerons, wt. 60 oz., motor: Aveox 1412 2Y, Prop: Aeronaut 8 X 5 folding ( plan to try a 9 X 5), Cells 10 1700's, Airfoil: stock - Performance: Hold on !!! Quick roll rate, vertical performance, 5 - 6.5 minutes flight times working the throttle. Will even slope in 15 mph winds I could probably build it lighter for even more exciting performance.

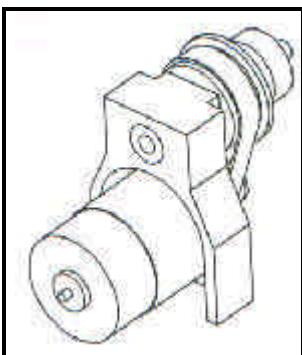

### The New ModelAir-Tech H-100 Belt Drive

Designed for use on the popular Speed 400 motors and the

Kyosho AP-29 this can be one potent little unit. It comes in ratios of - 3:1, 3.27:1, 3.6:1, 4:1, 4.36:1, and 4.8:1. Recommended for 5 - 14 cells! Don't you just wonder what this will do on the new Astro Flight Brushless motor? Sorry, no price came with the announcement. Send for their newest catalog. I'm sure it will be in there. ModelAir-Tech, P.O. Box 12033, Hauppauge, NY 11788-0818 Tel: (516) 979-1475 or E-mail Tom Hunt at THunt95147@aol.com

### Ai/Robotics On the Move

From Martin Euredjian comes news of a move to a new location. He wants to assure everyone that he's still there, doing his ESC thing with the FX-35D. His 80 mile move is difficult, for many reasons, but he's still out there for you. You can get hold of him at:

Ai/Robotics  
P.O. Box 34580  
Los Angeles, CA 90034  
(310) 815-1745  
(310) 815-1795 fax  
or E-mail at 72617.2465@compuserve.com

### A Buzz With a Rating

From: Dereck Woodward  
woodwadd@erols.com

As a long time Bee fanatic, I better get my bit in for the little fat fellow, the "Lazy Bee" by Clancy Aviation, with the 40" wing - four stars \*\*\*\* Astro 05G, seven or eight cells, prop 10 x 6 Master Airscrew electric wooden. Hitec micro RX, two Futaba 133 micro servos, 250 mAh nicad, Astro 210 controller. Weight - around 46 ounces. Controls:- rudder, elevator, motor. Performance:- Not the calm weather floater many think. It will do multiple rolls, loops, Cuban eights and a lot of stuff that isn't in the books and that only a Lazy Bee could stay in the air through. Strap on the floats in minutes and she's just as hot off the water. I only gave it four stars because I'm building a Speedy Bee and I want to see what life is like with ailerons! The Lazy bee is probably the most unique sports model in the air right now - one for the extrovert flier who loves to play in the weeds!

### Photos Needed!

Greg Gimlick, Current Affair columnist at R/C Report needs photos. He told me that "Gordon would like to increase the electrics coverage in RCR, but I'm rapidly running out of photos from my journeys. I'd love to show some projects, but I need pictures from folks..." You can reach Greg at:

76342.2271@compuserve.com or via snail mail at:

Greg Gimlick  
1016 Camberley Dr.  
Apex, NC 27502-8107

### Attention Members

**The February meeting will be at the Dublin Community Center, not at Ken's house. I'll have the pylon set-up and we'll do a bit more E RTP. I also plan to continue the talk from October on choosing the right prop. See you all at the Dublin Community Center, 7:30, Thursday, February 6th.**

To Reach Ken Myers, you can land mail to the address on the front page. My **E-mail address** is:  
102575.3410@compuserve.com  
**EFO WEBSITE:** <http://members.aol.com/KMyersEFO/>

### Upcoming Events:

**April 13, 1997** Capital Area Soaring Association's Annual **SPRING SIZZLER ELECTRIC FUN FLY**, Gude Drive Field, Rockville, Maryland, Call Roy Smith at 301-279-2966 for more information.

**June 7 & 8** Tenth Annual Lehigh Valley Radio Control Society E-Fly, Mike Stewart, 107 Taft Terrace, Washington, NJ 07882 as CD. For more info E-mail Mike at Mike721@worldnet.att.net or Phone: (908) 689-6981

**June 28/29 - Knights of the Air R/C Club**, Springfield, Illinois, Tim McDonough, 127 S. Oaklane Road, Springfield, Illinois 62707 (Email: tpm@inw.net)

**July 12/13 - Mid-America Electric Flies**, Ann Arbor Falcons/EFO, location, Midwest R/C Society Field, 5 Mi. Rd, Northville Twp, MI Ken Myers/Keith Shaw

**Aug. 2 - 5 - AMA Headquarters**, Muncie, IN Doug Ward, R.D. #1, Box 189, Irwin, PA 15642 (412) 446-5891  
DWard79207@aol.com

**September 20 & 21** Queen City Airport, Allentown, PA: KRC - setup on the 19th. For more info e-mail Anthony Assetto at 102723.2566@compuserve.com

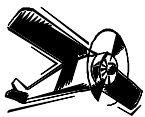

The Ampeer  
Ken Myers  
1911 Bradshaw Ct.  
Walled Lake, MI 48390

**Next Meeting: Thursday, Feb. 6, 1997,  
7:30 PM Dublin Community Center  
Just N. of Union Lake on Union Lake Rd.**