

The Officers:

President:

Ken Myers
1911 Bradshaw Ct.
Walled Lake, MI 48390
phone: (810) 669-8124

Vice-President:

Richard Utkan
240 Cabinet
Milford, MI 48381
phone: (810) 685-1705

Secretary/Treasurer:

Debbie McNeely
4720 Duck Lake Rd.
Milford, MI 48382
phone: (810) 685-1105

Board of Directors:

Keith Clark
2140 E. Highland Rd.
Howell, MI 4848843
phone: (517) 546-2462

Board of Directors:

Jeff Hauser
18200 Rosetta
East Point, MI 48021
phone: (810) 772-2499

Ampeer Editor:

Ken Myers
1911 Bradshaw Ct.
Walled Lake, MI 48390
phone: (810) 669-8124

Ampeer subscriptions are \$10 a year U.S. & Canada and \$17 a year world wide.

The Next Meeting:

**Thursday, March 7, 1996
Ken Myers's house - 1911 Bradshaw Ct.
Walled Lake, MI - Everyone Welcome!**

Using Speed 400 Motors in LMR applications:

By Doug Ingraham of Lofty Pursuits

I first encountered Graupner Speed 400 motors when I purchased a Timothy ARF glider from Hobby Lobby. I bought the plane because I needed a testbed for a new series of speed controls I was desiging to use with the Speed 400 class motors. I designed and built the prototype pylon racing (general use) control (LPSC-mini) and then installed it and the radio gear in the plane. I used the 7.2 volt Speed 400 direct drive with the 6x3 Graupner folder. I have tried lots of different battery setups but none of them gave great climb performance. Bob Boucher flew the plane and called the performance anemic <grin>. So the quest for more performance began.

There is no way the setup I mentioned above could be used in something like Class A sailplane (event 610) because you get only a little altitude in the 30 or 45 seconds of motor run in these events. I get lots of motor run with my setup. About 12 minutes of full throttle with the largest pack. However, I

wanted a setup where the plane would go up like a rocket. Was this possible with a Speed 400 type power system?

I wrote a computer program to model the whole power system so that RPM, Power output of the motor, and motor efficiency are generated for a given current. The computer model doesn't take into account the voltage drop as the batteries discharge. Nor does it address the increase in Rm as the temperature increases in the motor. This means that the output of this program is a bit optimistic.

Using a 7 cell Class A sailplane LMR event as the goal, let's look at the most common direct drive setups first. The goal is to have the highest power to weight ratio. For this reason I modeled the use of Sanyo N-270AA cells which have plenty of capacity for even a 60 (*16.2 amps maximum draw to get 1 minute motor run on a 270 mAh pack - km*) second motor run and still a reasonable internal resistance.

Please Note: The numbers in italics are provided by Ken Myers. His data is not "exactly" the same as the numbers derived by Doug, but they match very closely,

What's in this issue?

Speed 400 Motor - A Smartt Challenge - Glen Poole - New Things From ModelAir-Tech - Next EFO Meeting - Keith Shaw on his Horton IX - White Opaque Micafilm Blocks RF? - Bargain Batteries - Ampeer On-line a WWW site - Rocket Micro Pylon Racer

Ampeer

therefore the predictions should be valid. The smallest diameter prop to be used on a Timothy at 24 ounces should be 5.5 inches. I have added thrust estimations to some of Doug's figures when you see them. - km

Motor	Prop	Amps	RPM	Wout	Waste	Effic	Seconds	Notes
4.8V	6x3.5	21.7	14927	67.4	59.8	53.0%	45	Overloaded
4.8V	6x3	20.9	15796	68.6	55.9	55.1%	46	Overloaded
4.8V	5.5x1.5	16.2	21040	67.8	37.2	64.6%	60	Diameter to pitch ratio unusable
6V	6x3.5	11.3	13098	46.3	33.7	57.9%	86	Close to max output for this combination (9 oz/in thrust)
6V	6x3	10.7	13740	45.8	30.7	59.9%	91	(9.5 oz. thrust)
7.2V	7x3.5	9.0	9525	35.4	32.0	52.5%	108	(9 oz. thrust)
7.2V	6x3.5	7.0	11800	33.7	19.4	63.5%	139	(7 oz. thrust)
7.2V	6x3	6.5	12324	32.5	17.2	65.4%	150	Anemic!!! (7.5 oz. thrust)

No wonder Doug found the flights with the original power system marginal. 7.5 oz of thrust is just under the 1/3 value often given as the minimum thrust to weight ratio. The Timothy probably only succeeded because the plane is a glider type and wants to fly some anyway. Note that by changing to a 7x3.5 prop on the original setup the outcome might have been about the same as changing motors to use the 6x3, but let Doug continue... km

Two columns might need explanation. The Wout column which stands for watts out. This is the power that is delivered to the prop. The Waste column is the amount of watts that are wasted by being converted to heat by the motor. This is what heats the motor. I run at 20 watts waste for 6 minutes and no cooling air. 30 watts should be tolerable for a minute. Much more than that and the motor will cook itself very quickly. The efficiency column is the motor efficiency, not the system efficiency. The seconds column is a rough estimate of the motor run duration. All three of these setups weigh the same at 2.6 ounces for the motor, 3.5 ounces for the battery, and around 1 ounce for the ESC and prop for a total of 7.1 ounces. Based on these findings I replaced the 7.2 volt motor in my Timothy with the 6V motor and got an increase in power of almost 41% (13.3 watts more to the prop). Clearly there is no way you can run one of these motors at 21+amps so the 4.8 volt motor is not usable direct drive with the available props. By the way, the 6x3 prop is the Graupner 6x3 folder and the 6x3.5 is the Robbe 6x3.5 folder.

On direct drive it looks like the best we can do is about 46 watts with 7 cells.

Graupner sells a 4:1 gearbox with both the 6V and the 7.2V motors. They suggest a special 11x8 prop for it. Here are the numbers for all 3 motors on 7 cells. (Note: Hobby Lobby suggests 10 cells on the 7.2V motor and 8 cells on the 6V motor but we calculate it for 7 because we are limited to that by the rules.)

Motor	Prop	Amps	RPM	Wout	Waste	Effic	Seconds	Notes
4.8V	11x8	16.7	5090	69.7	37.9	64.8%	58	Overloaded
4.8V	11x7	16.2	5260	67.8	37.2	64.6%	60	(18 oz. thrust)
6V	15x7.5	12.0	2966	44.7	40.1	52.7%	81	(24 oz. thrust)
6V	11x8	7.7	4238	39.6	18.2	68.5%	126	(12 oz. thrust)
7.2V	16x8	9.0	2381	35.4	32	52.5%	108	(25 oz. thrust)
7.2V	11x8	4.5	3613	25.4	10.1	71.6%	216	(9.5 oz. thrust)
----- Hobby Lobby/Graupner Recommendations -----								
6V	15x7.5	14	3121	55.5	53.5	50.9%	69	8 cells
6V	11x8	9.2	4633	52.5	24.6	68.1%	106	8 cells
7.2V	16x8	13	2971	65.5	64.2	50.5%	75	10 cells
7.2V	11x8	7.3	4734	56.5	22.4	71.6%	133	10 cells

SPECIAL	11x8	9.8	4572	50.7	20.7	71.0%	99	7 cells

None of the standard motors is a good setup for 7 cells for *this task*. It is possible that the 6V motor with the large slow turning prop would produce a better climb than the 6x3 direct drive setup making the fact that it is down 6 watts a moot point. What is needed is a motor wind between the 4.8 volt and the 6 volt Graupner motors. Such a motor does exist (SPECIAL) but is not possible to get at this time. I had to return the sample I tested.

So what other possibilities are there? Plenty! In Hobby Lobby's catalog #26 they list 3 different ratios of inline reduction gearboxes. There is a 4:1 like the Graupner unit and a 5.25:1 and a 5.9:1. Matched with the 4.8V motor these should make lots of power. Here are my top few calculations for each ratio matched with an Aeronaut prop.

4:1 reduction with Graupner Speed 400 4.8V motor on 7 Sanyo N-270AA cells

Prop	Amps	RPM	Wout	Waste	Effic	Seconds	Notes
11x6.5	15.4	5439	68.4	33.2	67.3%	63	30-45 seconds?? (19 oz. thrust)
10.5x6	13.9	5846	65.0	27.9	70.0%	70	
10x7	13.6	5927	65.0	27.3	70.4%	71	
9x6.5	10.8	6687	57.2	19.8	74.3%	90	
9.5x5	10.6	6742	56.5	19.3	74.5%	92	
9x5	9.4	7067	51.8	16.7	75.6%	103	
8x5	7.2	7664	41.1	12.8	76.3%	135	Close to max effic.

5.25:1 reduction with Graupner Speed 400 4.8V motor on 7 Sanyo N-270AA cells

Prop	Amps	RPM	Wout	Waste	Effic	Seconds	Notes
12.5x10	16.2	3978	69.3	36.0	65.8%	60	??
13.5x7	15.9	4041	69.0	34.9	66.4%	61	??
13x6.5	14.6	4309	67.2	30.5	68.8%	66	
12.5x7.5	14.5	4330	67.0	30.2	68.9%	67	
12x8	13.9	4454	65.9	28.2	70.0%	70	
12.5x6.5	13.6	4516	65.2	27.4	70.4%	71	
12x7	13.1	4620	63.8	25.8	71.2%	74	
11.5x7	12.1	4826	61.4	23.1	72.7%	80	
11x6.5	10.7	5116	56.9	19.6	74.4%	91	
10.5x6	9.3	5405	51.4	16.6	75.6%	104	
10x7	9.1	5446	50.6	16.2	75.8%	107	
9.5x5	6.7	5943	38.8	12.2	76.1%	145	less than max effic.

5.9:1 reduction with Graupner Speed 400 4.8V motor on 7 Sanyo N-270AA cells

Prop	Amps	RPM	Wout	Waste	Effic	Seconds	Notes
14x8.5	15.8	3614	68.9	34.6	66.6%	62	
14x7	14.7	3816	67.4	30.9	68.6%	66	
12.5x10	14.1	3927	66.3	29.0	69.6%	69	
13.5x7	13.8	3982	65.7	28.0	70.1%	70	
13x6.5	12.5	4221	62.5	24.2	72.1%	78	
12.5x7.5	12.4	4239	62.3	23.9	72.3%	78	
12x8	11.9	4331	60.8	22.6	72.9%	82	
12.5x6.5	11.6	4386	59.9	21.8	73.3%	84	
12x7	11.1	4478	58.3	20.6	73.9%	88	
11.5x7	10.2	4644	55.0	18.4	74.9%	95	
11x6.5	8.9	4883	49.7	15.8	75.9%	109	
10.5x6	7.7	5104	44.1	13.7	76.3%	126	Near max effic.
10x7	7.5	5141	43.0	13.3	76.3%	130	Near max effic.
9.5x5	5.4	5527	31.3	10.6	74.7%	180	

So you like big props? This would be the ratio to try. You do have to keep in mind that there might be a clearance problem on some planes due to a short nose length. Timothy can handle 12" props. I have the 4:1 gearbox on order and I plan to carefully break in the brushes and advance the timing on the motor. The prop I am going to swing is the Aeronaut 11x6.5. (Look at the chart for the 4:1 gear ration and you can see that Doug is setting up this plane for super climb now at almost 2.5 times the thrust of the original. km) I am guessing that this is right on the edge of what I can get away with. If I used better batteries than the 270AA types I would drop down at least one and maybe 2 prop sizes because the motor terminal voltage will be quite a lot higher than with the 270AA cells. This would increase the RPM and the watts out

which might be enough to burn up the brushes. The simple way to advance the timing is to take the anticipated current and divide it by 10. Add this to the no-load current and then advance the timing so the no-load current matches it. If you don't do this I guarantee you will burn up the brushes.

Going to KR-600 AE cells will more than double the listed times and provide slightly higher Watt out and rpm figures. This would be the way I would go for the 1/2A demonstration event that has been proposed for the 96 Nats. It is a 2 minute LMR with an 8 minute flight duration and a spot landing similar to the Class A sailplane event in the AMA rulebook.

If you get a chance to try any of these things out I would love to hear from you. I can be reached by phone at 605 343-8760, Email on the internet at dpi@lofty.com, Email on CompuServe at 75116,473 and by US snail mail.

Special thanks to Larry Marshall for reviewing this article.

Doug Ingraham
2274 Aster Ct.
Rapid City, SD 57702

Note: In a recent conversation with Scott Chapman of Salt Creek Auto, 1-800-359-0233, he told me that the special 400 motor, that Doug talked about, is now available for about \$8.

THIRD ANNUAL ELECTRIC DURATION CHALLENGE

WHAT The objective is to keep an electric-powered airplane in the air as long as possible. Since this is a postal competition, your results should be mailed to the contest director.

WHY To do something that few United States pilots have done. Electric power technology is far beyond the typical 10-20 minute flight.

WHERE Any flat field in the United States or US Territories (no slope soaring/flying.) Multiple pilots are OK.

WHEN Anytime during the period from June 15th through June 23rd. You can fly as often as you wish during this nine-day window (including two full weekends).

CATEGORIES There are three competition categories: 1) Continuous motor run; 2) Ni-cad batteries only; and 3) Anything goes, period (however no extension cords are allowed!). For the continuous motor run the motor must be on during the entire flight. 200 foot maximum altitude.

ENTRIES Record your longest flight during the nine-day window. You and your witnesses sign the entry form. The entry form may be duplicated should you wish to enter in more than one category. Should you enter in more than one

category, you must have separate qualifying flights -- you can't enter one flight in more than one category. Post:marked no later than 25 June, 1996.

FEES The entry fee is \$5.00 per category, \$15.00 maximum. Make checks or money orders payable to "Duration Challenge." You can send the check with your contest entry form.

AWARDS A perpetual trophy goes to the longest flight. Awards will be presented to the winners in other categories. Subscriptions are being donated by Model Builder magazine and the competition will be written up by the magazine's electric columnist.

The Details

Be sure to fill in the entry form completely with the details about your entry: Number and type of cells, motor, series/parallel wiring, prop, gearbox, ready-to-fly weight, time of day, names of witnesses. In order to further duration flight we need to know how it's done. If you can, please send photos of your planes. Show the planes on the ground and/or a flight shot. Shots with a uniform background (blue sky, black asphalt, white or gray cloth, etc.) are great and reproduce well. If there are people in the pictures, please have them take off their hat and sunglasses.

Past winners include Hardy Benson (1995, 3 hours, 23 minutes) and Jerry Smartt (1994, 1 hour, 17 minutes). The world record is over 10 hours by Norbert Ladenburger of Germany.

Send entry forms to the contest CD, Jerry Smartt, Rt 3 Box 300, Warsaw MO 65355 or call (816) 438-5682, fax (816) 438-9573. Call Jerry for more information.



From Glen Poole

1624 Redpoll Ct.
Naperville, IL
60565-2319

Glen provided me with the information on Jerry's contest, and sent along some nice photos of some of his planes; Electra AF cobalt 05 geared, Mixette

(original) AF 15 geared, and Lanzo Bomber Trinity geared. Lanzo is pictured.

Duration Challenge

ENTRY FORM CATEGORY _____

AIRCRAFT FLIGHT TIME _____

WEIGHT RTF: _____

NUMBER OF CELLS _____

TYPE OF CELLS _____

SERIES/PARALLEL _____

MOTOR _____ PROP _____

GEARBOX/RATIO _____

FLIGHT CONDITIONS, TIME OF DAY, ETC.

CONSTRUCTION NOTES, OTHER INFO, SPEED CONTROL, TYPE OF COVERING

PILOT(PRINT) NAME AND ADDRESS

signature above

WITNESS(PRINT) NAME AND ADDRESS

signature above

YOU MUST DECLARE THE CATEGORY. EITHER ANYTHING GOES, NICADS, OR CONTINUOUS MOTOR RUN

MODELAIR-TECH R/C Model Aircraft Products and Engineering

P.O. Box 12033

Hauppauge, N.Y. 11788-0818

Phone+Fax: 516-979-1475

E-mail: THunt95147@aol.com

MODELAIR-TECH would like to make the announcement of yet another version of the very utilitarian H-1000 belt drive: A single or dual motor, co-axial, contra-rotating prop drive system.



The single motor unit, based on the Astro 40 geared motor, running on 24 cells is capable of a 1 to 1 thrust to weight ratio (motor and battery weight only) on only 25 amps draw. It swings a pair of medium pitch 13-14 inch diameter props at near 5000 rpm. Any geared motor with some shaft extending out the

rear end bell can be utilized. To date, only the Astro 25/40 and 60 come stock with 1/4 to 3/8 " of shaft out the back. The stock Astro gearbox is necessary to reverse the direction of the front prop. The motor is mounted rear-end forward onto a basic H-1000 housing. A pulley mounted to the rear of the shaft drives a 3/8" hollow tube rear prop shaft. The gearbox, mounted to the rear drives another belt system to a 1/4" solid shaft which passes through the hollow forward shaft to drive the front prop. Both shafts are ball bearing supported. The hollow shaft is supported on stock H-1000 bearing holders. The solid inner shaft is support near the gearbox end, on another bearing block. Up front where all the work is done, the 1/4 inch inner shaft is supported by a bearing located in the rear prop drive washer. Pretty neat

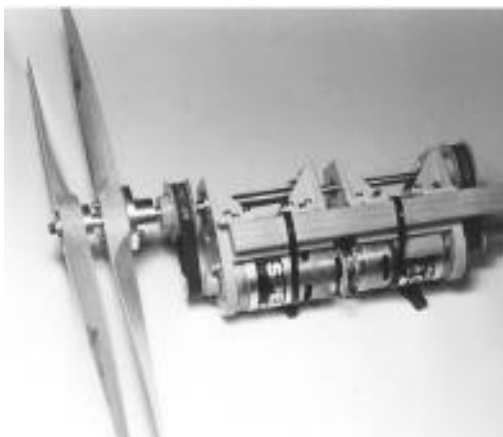

huh!!! 2.57/1 and 3.0/1 ratios are available for Astro 25 and 40's. Astro 60's (and 90's?) are probably practical in the 2.0-2.4/1 range.

The dual motor unit utilizes any

motor of the Speed 700 class or larger. Non-timeable motors (like the Speed series) are mounted back to front, in-line. This allows the front motor to be run normally driving the tractor rear prop. The rear motor facing backwards runs in the proper direction and drives a pusher front prop. The unit in the pictures utilizes the inexpensive Speed 700 9.6v motors. Running on 12 cells apiece at 3.0/1 ratio, together, they swing 16 x 6 props at about 5000 rpm for only 25 amps of current draw. Thrust from this set-up is around 5 lbs. Again a 1 to 1 thrust to weight ratio for the propulsion system!!! Varying ratios and props, during static testing, has shown a benefit to having a slightly higher pitch prop in the rear.

The single motor unit with the Astro 40 is capable of flying an 8-10 pound model. The dual unit with speed 700's or Astro 25's on 24-28 cells will fly models approaching 12 pounds.

Flight testing of these two units will commence sometime this spring.

Both these units will be made available on a special order basis only. Come to us with your ideas and we will design a unit specifically for YOUR application! Costs will range between \$95.00 and \$130.00 less motor(s).

Other New ModelAir-Tech Goodies for 1996

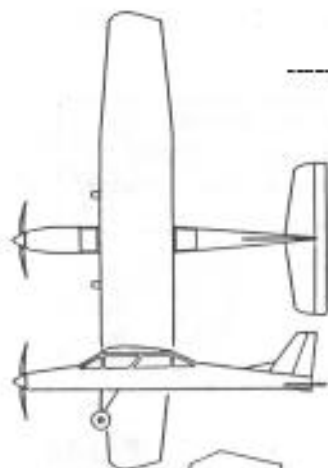

K101 Lowatt - "Sorta" Cessna, Pilatus Porter, 203 sq.in. wing area. 37.5" span for 3 ch. operation 5-8 cell 500 mAh battery & Speed 400 mtr. weight 14-20 oz. Kit: \$27.97 or plans \$8

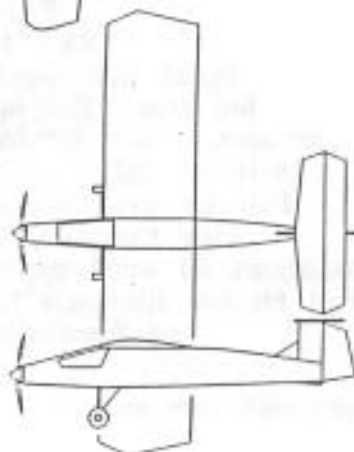

K102 Dimwatt High wing, T-tailed sport model wing area: 231 sq.in for 3 ch. operation 5-8 cell 500 mAh battery & Speed 400 mtr. weight 14-20 oz. Kit: \$27.97 or plans \$8

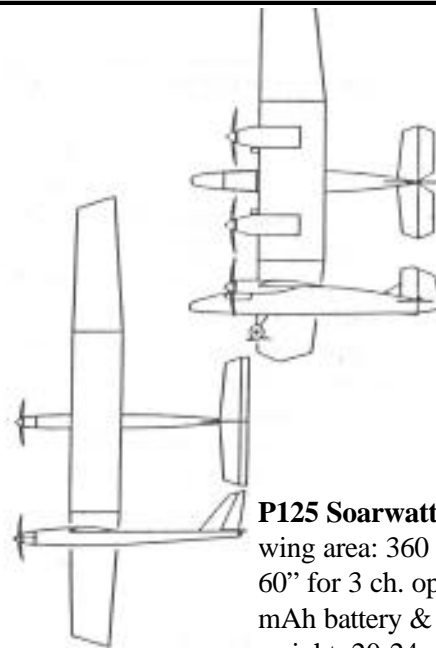

P124 Twin-Dimwatt Twin motor version of Dimwatt wing area: 250 sq.in, wing span: 38" for 3 ch operation on 8 cells, 600-800 mAh battery & Speed 400 motor weight: 22-26 oz Plans \$10.00

P125 Soarwatt - "Stick" Sailplane; wing area: 360 sq.in. wing span 60" for 3 ch. operation 7 cell 500 mAh battery & Speed 400 motor, weight: 20-24 oz. Plans \$8.00

P129 Defiant 430 - 430 sq.in., 64" span. For Speed 400 LMR events. Builds to less than 20 oz. with 7 cell 500 mAh pack and BEC SC. Fiberglass fuselage available. Wood fuselage not shown on plans. Plans \$10 - fuselage \$60



The Next EFO Meeting

The next EFO meeting will be at Ken Myers's house, 1911 Bradshaw Ct., Walled Lake, MI. Bradshaw Ct. is on the west side of Benstein Rd. between W. Maple Road and Glengary, closer to Glengary. I'll have out an orange marker on the east side of the road where you to turn west. Because of the bent of the conversation at the last meeting, we will be looking at the WWW, InterNet e-mail, CompuServe ModelNet and computer programs to aid the e-modeler. (No this is not becoming a Computer Club - this is a ONE time event!) Even if you don't own a computer, or could care less about computers, be sure to come. We, of course, will be discussing our latest projects, watching the rest of the KRC '94 video, having refreshments and doing our general electric thing.

The meeting will be on the regular day, first Thursday of month, March 7 at 7:30. The porch light and the coffee will be on - ya all come now, hear!

Keith Shaw's Horton IX

from a response to Adam Eberbach by Keith Shaw

Adam Eberbach of Melbourne, Australia wrote to Keith Shaw, via Ken Myers to ask Keith about his Horton, pictured below. Many of you have seen this plane fly. It is fast, furious and exciting. (Note: that's a 60-size Stearman on the left.)



What kind of project did this Horton turn out to be?

The Horten IX is probably the most complex design ever created, so I don't think it would be a good candidate for your project. The 262 (Adam said that he was considering this model) would be a MUCH easier project, with potentially better speed/performance per watt. Several reasons...

1. Pure wings must use some of their wing for yaw and pitch stability, so the effective wing area is at best about 70%.
2. The Horten's engines were completely inside the wing, this makes the Ducted Fan rotor tiny and even more inefficient. My Horten has a 62" span, 740 sq.in. of wing area, and weighs six pounds. Even at this size, the rotor is only 2.6 inches in diameter!
3. Designing a center section spar system was a nightmare, considering that it had to have two huge holes through it! Much careful carbon fiber and 1/64 ply work involved.
4. It has very little internal space, and is quite crowded. In fact, it's a good thing it's slingshot launched, as the battery completely fills the space required for a retracted nosewheel. It lands on skids.
5. Structurally, it's a nightmare, as every rib station is a different airfoil, different chord, different % thickness, and at a different angle of attack. The Horten aerodynamics use a "non-linear" wing twist system for the pitch and yaw stability. The physics of this would take me a book to explain, and I would be very surprised if the "Tailless Aircraft in Theory and Practice" book would cover it. Most books discuss only the classic "Northrop" and "Lippisch" approaches. My Horten knowledge unfortunately does not

come from any one source, it's the result of 15 years of researching obscure German Journals and manuscripts. The book "Nurflugel" has some usable information in it. Even with all the care and calculations, I was forced to add a small clear plastic fin after the first test flights. At high speed (100+mph) the canopy starts acting like a fin on the wrong end of the airplane! This is well above the maximum (scale) design speed of the original, so they probably never noticed the effect.

6. The airfoils are "Horten" designs, they look similar to the 23000 series, modified for zero pitching moment.
7. Pure wings can be VERY tough to fly, as there are no visual clues to orientation from the fuselage, tail or fin. 90% of the time all you see is a minute color stripe from the edge on view, and if it is camouflage....
8. Unless you are interested in pursuing designing and making your own fan units, you would need to make a much larger model to make use of commercial units. The Electro-Jet Tecnology fan seems to be the best available e-unit, 3.5 in rotor and reasonably efficient, puts out 20+ ounces thrust on 200 watts. However this would require a 7 foot span to fit the rotors inside the wing (wing area would be 1300sq.in.!) It would be twice the area, near twice the weight, and less thrust than my little Horten.
9. I strongly believe that everyone should "roll their own" with projects of this complexity. I don't have plans available for the airframe or fan units. For simple projects, for casual modellers, plans and kits are invaluable, but for these "top end" projects the background knowledge necessary to succeed is just too great.

The 262 project should be looking MUCH better now... Good luck on whatever e-project you tackle, Keith Shaw, 2756 Elmwood, Ann Arbor, MI 48104

Watch Out for Opaque White Micafilm

In the February 1996 *Model Builder* Francis Reynolds reported that white opaque Micafilm can actually block RF signals. This may seem a bit impossible, since it is supposedly not metallic, but as reported in the article, if it is heated in a microwave oven, its true heritage shows through as it sparked, snapped, crackled, shriveled and ended up full of holes! According to Francis's further test with a R/C transmitter and field strength meter, with a piece of opaque white Micafilm between, the RF reading changed drastically. Doug Ward, editor of *Watts Current*, brought this piece of info to my attention. Thanks Doug, and be forewarned. Note that all reference is to white opaque, none of the translucentes seemed to do this. If you're having a "radio problem" and you've used opaque white Micafilm, maybe you need a "different" color!?! Check it out.

A Letter from Gordy Stahl

9303 LeBeau Ct.

Louisville, KY 40299

Subject: Access to some Cheap Ni-Cads

2/4/96

Dear fellow E. Flyer

My reason for writing you is to let you know that I have a quantity of Sanyo SCRC pre-configured cells for sale. ... cheap. These cells are for the most part, unused and were originally configured in hard plastic packs as power supplies for cordless impact tools. They are "military specification quality" - which only means we probably already paid too much for them, and somewhat hints to who they were configured for in the first place! The reason they were discarded is that when the packs are dropped a jumper spot weld breaks and the sealed pack is dead and un-repairable.

I am not in the battery business in any way shape or form and I am friend and supporter of suppliers like Mr. Ni-cad and SR, but I have in the past offered the cells at Keith Shaw's E-Fly and others. I am not implying these cells are brand-new, like those you purchase from the store. I am saying they are great cells and plenty of flyers are using them.

My recent move to Louisville, KY has tied up my time with 'honey do's', so building or flying will have to wait.. - so I haven't been able to make the cells available and frankly it's a waste to have them just sitting around. I am only able to collect them twice a year and recently the packs have been upgraded from the 1400mAhs to the more exciting 1700's. My quantity is limited, so it's first come first gets 'em. Here's the deal:

1400mAh \$1.00 each (I have a ton of em.)

1000 mAh \$2.00 each (I have very few.)

1700 mAh \$2.00 each (I have a good qty.)

You pay UPS charge of approx. \$5

When you receive them, they will be out of their plastic case, still tabbed together. They will be naked cells other than the small cardboard tubes over each cell acting as an insulator. The 1700's have the same "E" stamped in the bottom and the others have the same markings your used to seeing, (it's a habit of Sanyo to mark all their cells). You simply peel off the poorly installed tabs and configure them to meet your needs.

Are they any good? Yep. I can tell you that many of the E-Models flown in the Milwaukee, Chicago and Ann Arbor areas are using these cells. You can reach me at my new home number after 8pm until 11pm or other times your probably get my machine.

Here's a tip: don just order 7. You know you need one pack flying, one cooling and one charging. For nearly the

same price of a cool looking pack form the store, you can get enough cells for all three packs. I will send some spares in case you get a couple bad cells, or I'll send replacements. Frankly it's just too much hassle to fool with sending a small quantity and the UPS charge is the same. As you probably suspect no one is supposed to get these other than the dump and that's a stupid waste, but that's government:

Give me call, even if you just want to talk, Gordy Stahl,
(502) 491-5001

One Word Too Many!

Ken Myers

There are many people who claim that I am too wordy at times, but hey, this one cost me an AVEOX! :-). It seems the the aforementioned Doug Ward, of Watts Current, wanted an answer as to why some motors are called 400, 540, 600 etc. I remembered reading it somewhere, so sent it to him and low and behold, he stated I had the right answer, just in the explanation I had one word too many to qualify for the AVEOX. Now ain't that something - that close but no cigar. Maybe next time. Doug, do ya still have that AVEOX or have you given it away in another or your great contests? (By the way folks - in case you missed it - the above should have probably been saved until next month - April you know!)

Ampeer On-line

Ken Myers

CompuServe 102575,3410

InterNet: 102575.3410@compuserve.com

http://ourworld.compuserve.com/homepages/i_fly_epower

To those of you without access to a computer and modem, the above is just plain jibberish (and to many, rubbish as well) but ... as they say in the ads "The World is Getting Connected".

There are several Ampeer subscribers who are now only receiving the on-line version. Why would you want the on-line version, when you can't even take it to the "reading room" with you (unless maybe you're Bill Gates)? Well, you can (humph - odd choice of words). Just print it out, all or a part of it, and you once again have a 100% portable Ampeer text, graphs, photos and all.

In case you haven't realized it, all of the monies received for the Ampeer go to printing, postage and associated costs. The U.S. subscribers are slightly supporting the Canadian and world subscribers and a few selected newsletters and manufacturers. A typical U.S. issue costs \$0.20 printing

and \$0.32 postage for a total of \$0.52, Canadian total is \$0.72 per issue, and world is \$1.20 per issue. Throw in envelopes for mailing outside the U.S., mailing labels, computer paper, an occasional ink cartridge, and some back issues sent to "new" subscribers and it's just a break even proposition, which is what it is supposed to be!

Putting the Ampeer on-line eliminates the "cost of publishing". The only cost to us (the EFO) is the upload (to place on an on-line server) time, which is minimal. You, the subscriber, pay on your end for the connect time (time you are connected to a server) of your provider. For example: CompuServe charges \$9.95 a month for the first five hours of connect time. It usually takes no more than 5 minutes to download (suck onto your hard disk) an Ampeer, therefore the cost to you is about \$0.17 per issue. Twelve issues of the Ampeer would then cost you about \$2.00. That is a savings of \$8 a year off the cover price. By setting aside this tremendous savings you could buy a 1996 Pentium 166 machine in only 500 years!!!

For those of you already receiving the Ampeer on-line, and for those of you who wish to start, the procedure will now be (after this month - March) to use your InterNet browser to go to my home page site and download it. **I will no longer be sending it to you directly via CompuServe mail.** When you have download it, drop me a note, letting me know that you have it.

All of the above was written a bit tongue-in-cheek but the following are the real reasons why you should collect the Ampeer on-line:

1. It will free up a bit of my time, not having to staple, fold, stuff envelopes, put on mailing labels, etc. for so many newsletters.

2. You will get it faster. It will be uploaded the same weekend I take it to the printer. The Ampeer goes to the printer the Saturday before the last Thursday of the month.

3. You can easily "archive" several issues onto a 3.5" high density floppy disk, thus saving hard disk space and paper clutter. They run just fine off of floppies.

4. You get color pictures when available.

5. You can search for key words.

6. You can add to your collection of Ampeers, since the "current edition" will be available up to the weekend before I put on the new issue, then a back issue will be available on the WWW site for the remainder of the month, until the "new" issue is put on. (Since this is not a "real" WWW site, CompuServe only allows me 1Meg of space on their server, and with the Keith Shaw's talk on there, I don't have enough room to store a current issue and a back issue.)

7. By visiting my home page, you can be kept current with other electric happenings. Right now there is a connection to an electric page in Arizona, and I know of

others on the way. I have reformatted my home page to make it easy for you to see, at a glance, what has been updated since your last visit.

7. The InterNet is universal to any computer that can run a browser and the Adobe Acrobat .pdf format is also machine independent.

Club members with computer access to the WWW please let me know, so that I can stop mailing you the hard copy as well.

The EFO has been, and will continue to be, on the cutting edge of technology in all areas. Welcome to the future - the future is electric!!!

Hard copy readers, never fear! The Ampeer will keep coming to your door via the US and other postal agencies.

Rocket Micro-Pylon Racer
from Bill Griggs
RR2 Box 64
Canastota, N.Y. 13032
(315) 697-8152
CompuServe 102341.2605

Hi Ken,

I was wondering if you could add me to your list of electric suppliers. Here is the info on the **Rocket** micro pylon racer, for Speed 400 motors. Several people have inquired about my **Rocket** micro pylon racer kit for speed 400 motors. A complete kit is now available or just plans and cores.

The Rockets specifications are as follows.

Span: 28" ; Area: 135" Weight: 15-17 ounces (mine weighs 15.5 ounces) Don Belfort's weighs about 13.25 ounces; Motor: Graupner Speed 400 - 6 Volt version; Batteries: (6) KR-600 AE

Construction is foam and balsa wing, with a built up fuselage. Plans show built-up wing also.

I have modified the Rocket for three years and now have, what I believe, the right combination of control and speed. The wing span and aspect ratio have increased. Washout has been added to the cores and the tail length has been increased by an inch. My construction time is about 8 hours, not counting glue drying. You will probably take about 12 hours.

Plans are \$10; Plans & cores \$20; The Kit \$40

The kit includes, plans, cores, sheeting, band sawn parts, instructions everything needed except hardware (screws, clevises etc).

Express mail on the kit is only \$3 - First class mail isn't much cheaper. **Send a check or money order.**

Now I've Heightened Your Interest Here's some news from Europe, from Gordon Tarling editor: EFUK

Speed 400 Racers are becoming VERY popular over here. I can't really see why, though, as some of them are real pigs to fly until they get moving.

What is the best set up? Define 'best' for me and I'll try to

advise! Seriously, it all depends on what you want to do with the model. If you want to win races, all the serious boys over here use the 6 Volt motor with 7 x 700AR cells and the Graupner 6 x 6 (I think) Cam prop cut down to 5.5 inches or so. They fine tune the prop to give the required four minutes racing time plus around 20 seconds. If you want the model purely as a fun-fly and aerobatic machine, use the 7.2 Volt motor and seven cells of your choice - 600AA or 500AR are good. Prop to give required performance.

Now, if you ask me what is the best motor control to use, I may be able to tell you <G>. (*Gordon builds and sells a mighty fine controller for these motors - contact him at: 87 Cowley Mill Rd., Uxbridge, Middlesex, Great Britain, UB8 2QD compuserve 100554,2174 or phone or FAX 01895 251551*)

Those winning the races are all using my own Micro-Star 20. They only give problems after being flattened by a battery or such like!

I'd be most grateful for more details of this model you've ordered, as I don't think I've heard of it before. (*Yes I've got the Rocket ordered - so you'll all hear more about it. km*)A photo for the magazine would also be appreciated, when you've got it built.

Regards,
Gordon

Upcoming Events:

April 12-14 Toledo R/C Expo (need I say more!)

May 18/19 Memphis in May Fly-In, LMR events, All Up/Last Down, & more, Bills Jenkins (901) 362-2119

June 1 & 2 Mid-America Electric Flies, Saline, MI, Relaxed Fun Flying, All Up/Last Down, special awards, Ken Myers, (810) 669-8124 CompuServe 102575,3410 or InterNet 102575.3410@compuserve.com (**NOTE: event moved to June this year!**)

June 15 through June 23, 3rd Annual Electric Duration Challenge, any flat field in the US or its territories, Jerry Smartt, (816) 438-5682 (See rules March Ampeer)

July 20-22 Electric Nationals, AMA Headquarters Site, Muncie, IN, contact Ken Myers

Sept. 13-15, KRC Electric Fly-in, Quakertown, Pa.

Oct. 5 & 6 DEAF Fly-In, LMR events & All Up/Last Down, highest RC, weight lifting, Dallas RC Club field, Seagoville, TX, Greg Judy (817) 468-0962

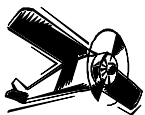

The Ampeer
Ken Myers
1911 Bradshaw Ct.
Walled Lake, MI 48390

**Next Meeting:
Ken Myers's house
Thursday, March 7 - 7:30**